

PUNCHES AND DIES FOR MACHINES PEDDINGHAUS



wromet.com.pl

TOOLS FOR MACHINES PEDDINGHAUS

A	Stempel u. Matrizen zur Stempelschnellspannvorrichtung	<p style="text-align: center;"> Peddicat 360/361 Peddiworker 500/600 Peddiworker 800 Peddimaster 60/80 Peddimaster 80/110 Hydraulic 300/500 Forax 15 – 25 – 45 – 65 – 150 – 250 – 450, 225 B/11– 13 – 45 – 60, 225 H/11 – 13 210 Standard 11 – 13, 210 SUPER 11 – 13, Hydraulic60 – 600 – 40, Stanzfix Peddimaster 450 M, Peddimaster 28/40 – 40/60 – Peddimaster 60/100 – Peddiworker 400 – 600 </p>		
B	Stempel u. Matrizen zur Stempelschnellspannvorrichtung	<table style="width: 100%; border: none;"> <tr> <td style="width: 50%; vertical-align: top;"> Peddicat No. 1 Peddicat 361 Peddicat 380 Peddicat 500 Peddiworker No. 1 Peddiworker 501 Peddiworker 502 Peddiworker 801/802 Hydraulic 100 Hydraulic 280 Hydraulic 301 Hydraulic 501 Hydraulic 502 Hydraulic 800 </td> <td style="width: 50%; vertical-align: top;"> Hydraulic 1000/1001 Peddimaster 800/1100 Peddimaster 1100/1700 Peddimaster 110/170 Peddimaster 60/100 H Peddiworker 1000 G Peddimax 110/140 Peddimax 600 Peddimax 601 Peddimax 602 Peddimax 800 Peddimax 801 Peddimax 1002 Peddimaster 100/160 H Forax 80 – 100 – 1000, 225 B/16 – 20 – 80 – 100, 225 H/16 – 20 210 Standard 16, 210 SUPER 16 – 20 </td> </tr> </table>	Peddicat No. 1 Peddicat 361 Peddicat 380 Peddicat 500 Peddiworker No. 1 Peddiworker 501 Peddiworker 502 Peddiworker 801/802 Hydraulic 100 Hydraulic 280 Hydraulic 301 Hydraulic 501 Hydraulic 502 Hydraulic 800	Hydraulic 1000/1001 Peddimaster 800/1100 Peddimaster 1100/1700 Peddimaster 110/170 Peddimaster 60/100 H Peddiworker 1000 G Peddimax 110/140 Peddimax 600 Peddimax 601 Peddimax 602 Peddimax 800 Peddimax 801 Peddimax 1002 Peddimaster 100/160 H Forax 80 – 100 – 1000, 225 B/16 – 20 – 80 – 100, 225 H/16 – 20 210 Standard 16, 210 SUPER 16 – 20
Peddicat No. 1 Peddicat 361 Peddicat 380 Peddicat 500 Peddiworker No. 1 Peddiworker 501 Peddiworker 502 Peddiworker 801/802 Hydraulic 100 Hydraulic 280 Hydraulic 301 Hydraulic 501 Hydraulic 502 Hydraulic 800	Hydraulic 1000/1001 Peddimaster 800/1100 Peddimaster 1100/1700 Peddimaster 110/170 Peddimaster 60/100 H Peddiworker 1000 G Peddimax 110/140 Peddimax 600 Peddimax 601 Peddimax 602 Peddimax 800 Peddimax 801 Peddimax 1002 Peddimaster 100/160 H Forax 80 – 100 – 1000, 225 B/16 – 20 – 80 – 100, 225 H/16 – 20 210 Standard 16, 210 SUPER 16 – 20			
C	Stempel u. Matrizen zur Stempelschnellspannvorrichtung	<p style="text-align: center;">Sonderstanzvorrichtung bis 39 – 58 – 90 für alle Modelle</p> <p style="text-align: center;"> Hydraulic 1000 N Hydraulic 1400 N 225 B/25 – 130 Hydraulic – 140 210 SUPER 25 </p> <p style="text-align: center;">Zur Sonderstanzvorrichtung für alle Modelle und Größen</p>		

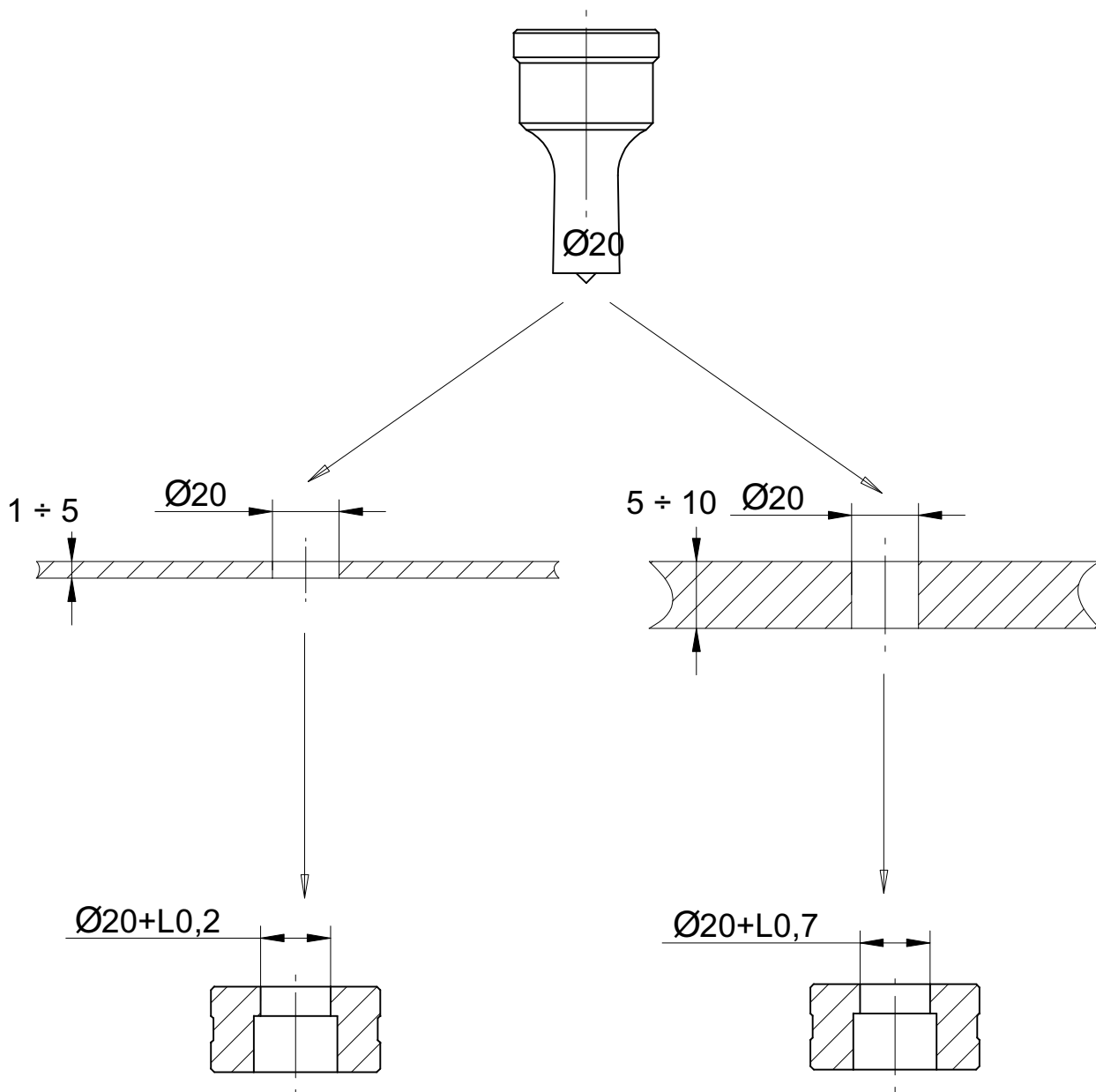

A stamp determines the size of the hole.
The hole in the matrix corresponds to the size of stamp + clearance.
For the manufacture of thin sheet of 0.2 mm to 0.7 mm thick plates.
It is possible to punch and die with special dimensions and with individual bulk.

	<p>Round punch \varnothing (mm)</p> <table border="1"> <tbody> <tr><td>3,0</td><td>6,0</td><td>9,0</td><td>12,0</td></tr> <tr><td>3,5</td><td>6,5</td><td>9,5</td><td>12,5</td></tr> <tr><td>4,0</td><td>7,0</td><td>10,0</td><td>13,0</td></tr> <tr><td>4,5</td><td>7,5</td><td>10,5</td><td>13,5</td></tr> <tr><td>5,0</td><td>8,0</td><td>11,0</td><td>14,0</td></tr> <tr><td>5,5</td><td>8,5</td><td>11,5</td><td></td></tr> </tbody> </table>	3,0	6,0	9,0	12,0	3,5	6,5	9,5	12,5	4,0	7,0	10,0	13,0	4,5	7,5	10,5	13,5	5,0	8,0	11,0	14,0	5,5	8,5	11,5		<p>NR 1</p>												
3,0	6,0	9,0	12,0																																			
3,5	6,5	9,5	12,5																																			
4,0	7,0	10,0	13,0																																			
4,5	7,5	10,5	13,5																																			
5,0	8,0	11,0	14,0																																			
5,5	8,5	11,5																																				
		<p>C</p>																																				
	<p>Oval punch (mm)</p> <table border="1"> <tbody> <tr><td>3,0</td><td>6,0</td><td>9,0</td><td>12,0</td><td>15,0</td><td>18,0</td></tr> <tr><td>3,5</td><td>6,5</td><td>9,5</td><td>12,5</td><td>15,5</td><td>18,5</td></tr> <tr><td>4,0</td><td>7,0</td><td>10,0</td><td>13,0</td><td>16,0</td><td>19,0</td></tr> <tr><td>4,5</td><td>7,5</td><td>10,5</td><td>13,5</td><td>16,5</td><td></td></tr> <tr><td>5,0</td><td>8,0</td><td>11,0</td><td>14,0</td><td>17,0</td><td></td></tr> <tr><td>5,5</td><td>8,5</td><td>11,5</td><td>14,5</td><td>17,5</td><td></td></tr> </tbody> </table>	3,0	6,0	9,0	12,0	15,0	18,0	3,5	6,5	9,5	12,5	15,5	18,5	4,0	7,0	10,0	13,0	16,0	19,0	4,5	7,5	10,5	13,5	16,5		5,0	8,0	11,0	14,0	17,0		5,5	8,5	11,5	14,5	17,5		<p>NR 2</p>
3,0	6,0	9,0	12,0	15,0	18,0																																	
3,5	6,5	9,5	12,5	15,5	18,5																																	
4,0	7,0	10,0	13,0	16,0	19,0																																	
4,5	7,5	10,5	13,5	16,5																																		
5,0	8,0	11,0	14,0	17,0																																		
5,5	8,5	11,5	14,5	17,5																																		
		<p>C</p>																																				
	<p>Oval punch \varnothing (mm)</p> <table border="1"> <tbody> <tr><td>5,0x10,0</td><td>6,5x18,0</td></tr> <tr><td>5,0x14,0</td><td>7,5x14,0</td></tr> <tr><td>5,5x10,0</td><td>9,0x14,0</td></tr> <tr><td>5,5x14,0</td><td>9,0x18,0</td></tr> <tr><td>5,5x19,0</td><td>10,0x14,0</td></tr> <tr><td>6,5x12,0</td><td></td></tr> </tbody> </table>	5,0x10,0	6,5x18,0	5,0x14,0	7,5x14,0	5,5x10,0	9,0x14,0	5,5x14,0	9,0x18,0	5,5x19,0	10,0x14,0	6,5x12,0		<p>NR 2</p>																								
5,0x10,0	6,5x18,0																																					
5,0x14,0	7,5x14,0																																					
5,5x10,0	9,0x14,0																																					
5,5x14,0	9,0x18,0																																					
5,5x19,0	10,0x14,0																																					
6,5x12,0																																						
		<p>C</p>																																				
	<p>Square punch (mm)</p> <table border="1"> <tbody> <tr><td>4,0</td><td>9,0</td></tr> <tr><td>5,0</td><td>10,0</td></tr> <tr><td>6,0</td><td>11,0</td></tr> <tr><td>7,0</td><td>12,0</td></tr> <tr><td>8,0</td><td>13,0</td></tr> </tbody> </table>	4,0	9,0	5,0	10,0	6,0	11,0	7,0	12,0	8,0	13,0	<p>NR 2</p>																										
4,0	9,0																																					
5,0	10,0																																					
6,0	11,0																																					
7,0	12,0																																					
8,0	13,0																																					
		<p>C</p>																																				
	<p>Rectangular punch (mm)</p> <table border="1"> <tbody> <tr><td>3x4+3x18</td><td>9x10+9x16</td></tr> <tr><td>4x5+4x18</td><td>10x11+10x16</td></tr> <tr><td>5x6+5x18</td><td>11x12+11x15</td></tr> <tr><td>6x7+6x18</td><td>12x13+12x14</td></tr> <tr><td>7x8+7x17</td><td></td></tr> <tr><td>8x9+8x17</td><td></td></tr> </tbody> </table>	3x4+3x18	9x10+9x16	4x5+4x18	10x11+10x16	5x6+5x18	11x12+11x15	6x7+6x18	12x13+12x14	7x8+7x17		8x9+8x17		<p>NR 2</p>																								
3x4+3x18	9x10+9x16																																					
4x5+4x18	10x11+10x16																																					
5x6+5x18	11x12+11x15																																					
6x7+6x18	12x13+12x14																																					
7x8+7x17																																						
8x9+8x17																																						
		<p>C</p>																																				

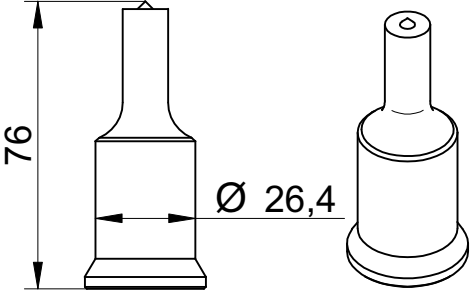
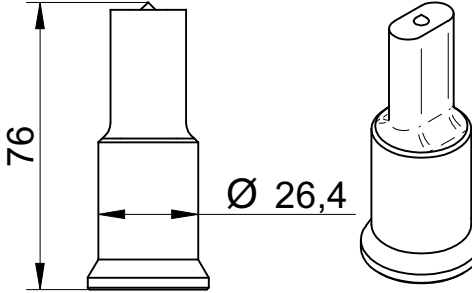
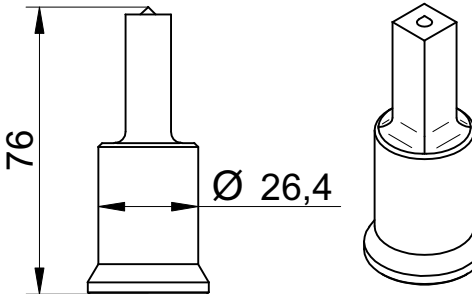
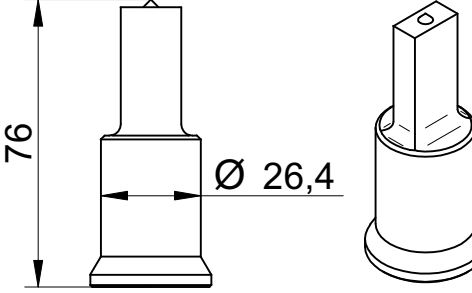
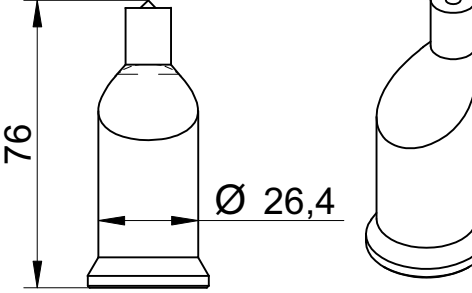
	<p>Round punch \varnothing (mm)</p> <p>5,0 ÷ 26,0 Size at 0.5 mm</p>	<p>NR 3</p> <p>C</p>															
	<p>Oval punch (mm)</p> <p>5,0x10,0 ÷ 10,0x19,0 Size at 0.5 mm</p>	<p>NR 3</p> <p>C</p>															
	<p>Square punch (mm)</p> <table border="1" data-bbox="730 1046 1107 1196"> <tbody> <tr><td>8,0</td><td>13,0</td><td>18,0</td></tr> <tr><td>9,0</td><td>14,0</td><td></td></tr> <tr><td>10,0</td><td>15,0</td><td></td></tr> <tr><td>11,0</td><td>16,0</td><td></td></tr> <tr><td>12,0</td><td>17,0</td><td></td></tr> </tbody> </table>	8,0	13,0	18,0	9,0	14,0		10,0	15,0		11,0	16,0		12,0	17,0		<p>NR 3</p> <p>C</p>
8,0	13,0	18,0															
9,0	14,0																
10,0	15,0																
11,0	16,0																
12,0	17,0																
	<p>Rectangular punch (mm)</p> <table border="1" data-bbox="730 1388 1165 1547"> <tbody> <tr><td>8x9÷8x24</td><td>13x14÷13x22</td></tr> <tr><td>9x10÷9x24</td><td>14x15÷14x21</td></tr> <tr><td>10x11÷10x24</td><td>15x16÷15x20</td></tr> <tr><td>11x12÷11x23</td><td>16x17÷16x19</td></tr> <tr><td>12x13÷12x23</td><td>17x18÷17x19</td></tr> </tbody> </table>	8x9÷8x24	13x14÷13x22	9x10÷9x24	14x15÷14x21	10x11÷10x24	15x16÷15x20	11x12÷11x23	16x17÷16x19	12x13÷12x23	17x18÷17x19	<p>NR 3</p> <p>C</p>					
8x9÷8x24	13x14÷13x22																
9x10÷9x24	14x15÷14x21																
10x11÷10x24	15x16÷15x20																
11x12÷11x23	16x17÷16x19																
12x13÷12x23	17x18÷17x19																
	<p>Punch eccentric (mm)</p> <table border="1" data-bbox="730 1753 976 1912"> <tbody> <tr><td>8,0</td><td>13,0</td></tr> <tr><td>9,0</td><td>14,0</td></tr> <tr><td>10,0</td><td>15,0</td></tr> <tr><td>11,0</td><td></td></tr> <tr><td>12,0</td><td></td></tr> </tbody> </table>	8,0	13,0	9,0	14,0	10,0	15,0	11,0		12,0		<p>NR 3</p> <p>C</p>					
8,0	13,0																
9,0	14,0																
10,0	15,0																
11,0																	
12,0																	

	<p>Round punch \varnothing (mm)</p> <p>5,0 ÷ 26,0 Size at 0.5 mm</p>	<p>NR 4</p> <p>A</p>															
	<p>Oval punch (mm)</p> <p>5,0x10,0 ÷ 10,0x19,0 Size at 0.5 mm</p>	<p>NR 4</p> <p>A</p>															
	<p>Square punch (mm)</p> <table border="1"> <tbody> <tr><td>8,0</td><td>13,0</td><td>18,0</td></tr> <tr><td>9,0</td><td>14,0</td><td></td></tr> <tr><td>10,0</td><td>15,0</td><td></td></tr> <tr><td>11,0</td><td>16,0</td><td></td></tr> <tr><td>12,0</td><td>17,0</td><td></td></tr> </tbody> </table>	8,0	13,0	18,0	9,0	14,0		10,0	15,0		11,0	16,0		12,0	17,0		<p>NR 4</p> <p>A</p>
8,0	13,0	18,0															
9,0	14,0																
10,0	15,0																
11,0	16,0																
12,0	17,0																
	<p>Rectangular punch (mm)</p> <table border="1"> <tbody> <tr><td>8x9÷8x24</td><td>13x14÷13x22</td></tr> <tr><td>9x10÷9x24</td><td>14x15÷14x21</td></tr> <tr><td>10x11÷10x24</td><td>15x16÷15x20</td></tr> <tr><td>11x12÷11x23</td><td>16x17÷16x19</td></tr> <tr><td>12x13÷12x23</td><td>17x18÷17x19</td></tr> </tbody> </table>	8x9÷8x24	13x14÷13x22	9x10÷9x24	14x15÷14x21	10x11÷10x24	15x16÷15x20	11x12÷11x23	16x17÷16x19	12x13÷12x23	17x18÷17x19	<p>NR 4</p> <p>A</p>					
8x9÷8x24	13x14÷13x22																
9x10÷9x24	14x15÷14x21																
10x11÷10x24	15x16÷15x20																
11x12÷11x23	16x17÷16x19																
12x13÷12x23	17x18÷17x19																
	<p>Punch eccentric (mm)</p> <table border="1"> <tbody> <tr><td>8,0</td><td>13,0</td></tr> <tr><td>9,0</td><td>14,0</td></tr> <tr><td>10,0</td><td>15,0</td></tr> <tr><td>11,0</td><td></td></tr> <tr><td>12,0</td><td></td></tr> </tbody> </table>	8,0	13,0	9,0	14,0	10,0	15,0	11,0		12,0		<p>NR 4</p> <p>A</p>					
8,0	13,0																
9,0	14,0																
10,0	15,0																
11,0																	
12,0																	

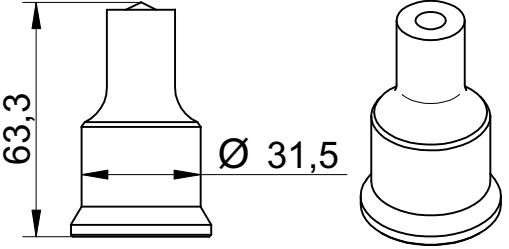
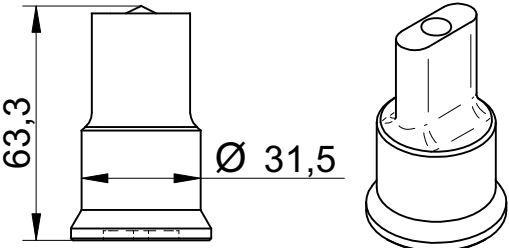
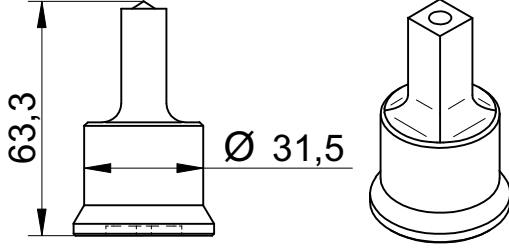
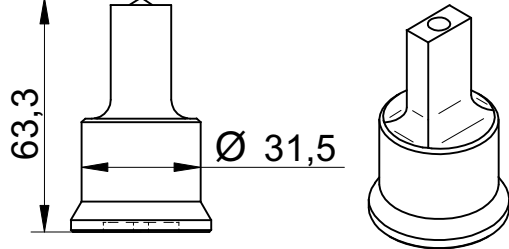
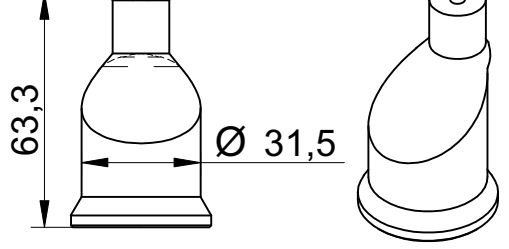
	<p>Round punch \varnothing(mm)</p> <p>3,0 ÷ 30,5 Size at 1 mm</p>	<p>NR 5</p> <p>B</p>														
	<p>Oval punch (mm)</p> <p>5,5x10 ÷ 22,0x31,0 Size at 1 mm</p>	<p>NR 5</p> <p>B</p>														
	<p>Square punch (mm)</p> <p>6,0 ÷ 22,0 Size at 1 mm</p>	<p>NR 5</p> <p>B</p>														
	<p>Rectangular punch (mm)</p> <table border="1" data-bbox="734 1388 1165 1601"> <tbody> <tr> <td>8x9÷8x26</td> <td>15x16÷15x26</td> </tr> <tr> <td>9x10÷9x24</td> <td>16x17÷16x26</td> </tr> <tr> <td>10x11÷10x26</td> <td>17x18÷17x25</td> </tr> <tr> <td>11x12÷11x26</td> <td>18x19÷18x25</td> </tr> <tr> <td>12x13÷12x26</td> <td>19x20÷20x24</td> </tr> <tr> <td>13x14÷13x26</td> <td></td> </tr> <tr> <td>14x15÷14x26</td> <td></td> </tr> </tbody> </table>	8x9÷8x26	15x16÷15x26	9x10÷9x24	16x17÷16x26	10x11÷10x26	17x18÷17x25	11x12÷11x26	18x19÷18x25	12x13÷12x26	19x20÷20x24	13x14÷13x26		14x15÷14x26		<p>NR 5</p> <p>B</p>
8x9÷8x26	15x16÷15x26															
9x10÷9x24	16x17÷16x26															
10x11÷10x26	17x18÷17x25															
11x12÷11x26	18x19÷18x25															
12x13÷12x26	19x20÷20x24															
13x14÷13x26																
14x15÷14x26																
	<p>Punch eccentric (mm)</p> <table border="1" data-bbox="734 1758 965 1915"> <tbody> <tr> <td>8,0</td> <td>13,0</td> </tr> <tr> <td>9,0</td> <td>14,0</td> </tr> <tr> <td>10,0</td> <td>15,0</td> </tr> <tr> <td>11,0</td> <td></td> </tr> <tr> <td>12,0</td> <td></td> </tr> </tbody> </table>	8,0	13,0	9,0	14,0	10,0	15,0	11,0		12,0		<p>NR 5</p> <p>B</p>				
8,0	13,0															
9,0	14,0															
10,0	15,0															
11,0																
12,0																

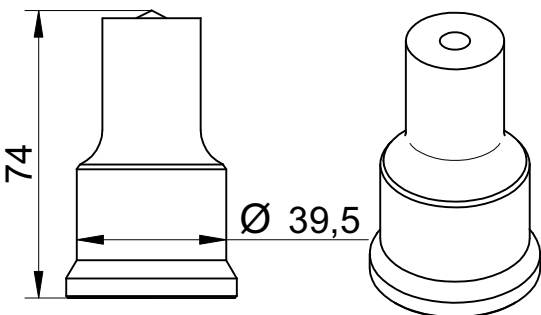
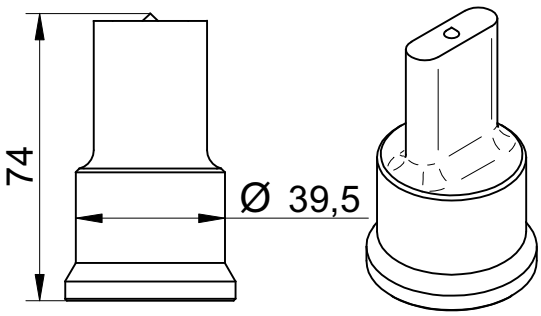
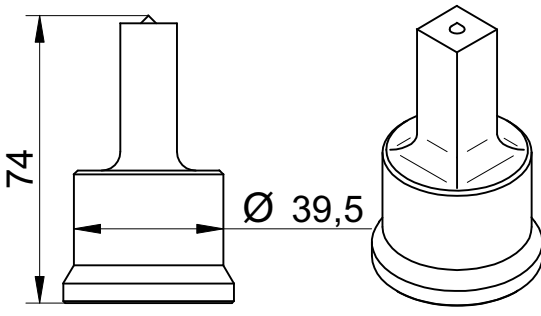
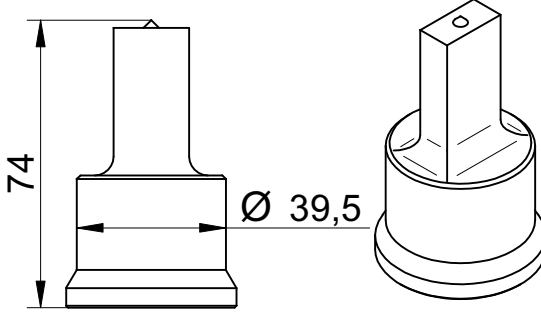
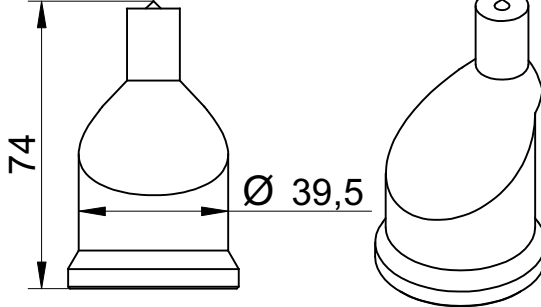
	<p>Round punch \varnothing(mm)</p> <p>3,0 ÷ 39,5 Size at 0,5 mm</p>	<p>NR 6</p>															
	<p>Oval punch (mm)</p> <p>5,5x10 ÷ 22,0x39,0 Size at 0,5 mm</p>	<p>NR 6</p>															
	<p>Square punch (mm)</p> <p>6,0 ÷ 28,0 Size at 1 mm</p>	<p>NR 6</p>															
	<p>Rectangular punch (mm)</p> <table border="1" data-bbox="742 1377 1189 1601"> <tbody> <tr> <td>8x9÷8x26</td> <td>15x16÷15x32</td> </tr> <tr> <td>9x10÷9x32</td> <td>16x17÷16x32</td> </tr> <tr> <td>10x11÷10x32</td> <td>17x18÷17x32</td> </tr> <tr> <td>11x12÷11x32</td> <td>18x19÷18x32</td> </tr> <tr> <td>12x13÷12x32</td> <td>19x20÷20x32</td> </tr> <tr> <td>13x14÷13x32</td> <td>24x25÷24x30</td> </tr> <tr> <td>14x15÷14x32</td> <td></td> </tr> </tbody> </table>	8x9÷8x26	15x16÷15x32	9x10÷9x32	16x17÷16x32	10x11÷10x32	17x18÷17x32	11x12÷11x32	18x19÷18x32	12x13÷12x32	19x20÷20x32	13x14÷13x32	24x25÷24x30	14x15÷14x32		<p>NR 6</p>	
8x9÷8x26	15x16÷15x32																
9x10÷9x32	16x17÷16x32																
10x11÷10x32	17x18÷17x32																
11x12÷11x32	18x19÷18x32																
12x13÷12x32	19x20÷20x32																
13x14÷13x32	24x25÷24x30																
14x15÷14x32																	
	<p>Punch eccentric (mm)</p> <table border="1" data-bbox="742 1758 1141 1915"> <tbody> <tr> <td>8,0</td> <td>13,0</td> <td>18,0</td> </tr> <tr> <td>9,0</td> <td>14,0</td> <td>19,0</td> </tr> <tr> <td>10,0</td> <td>15,0</td> <td>20,0</td> </tr> <tr> <td>11,0</td> <td>16,0</td> <td></td> </tr> <tr> <td>12,0</td> <td>17,0</td> <td></td> </tr> </tbody> </table>	8,0	13,0	18,0	9,0	14,0	19,0	10,0	15,0	20,0	11,0	16,0		12,0	17,0		<p>NR 6</p>
8,0	13,0	18,0															
9,0	14,0	19,0															
10,0	15,0	20,0															
11,0	16,0																
12,0	17,0																

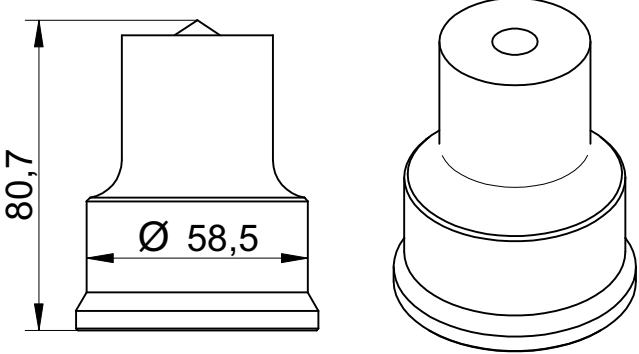
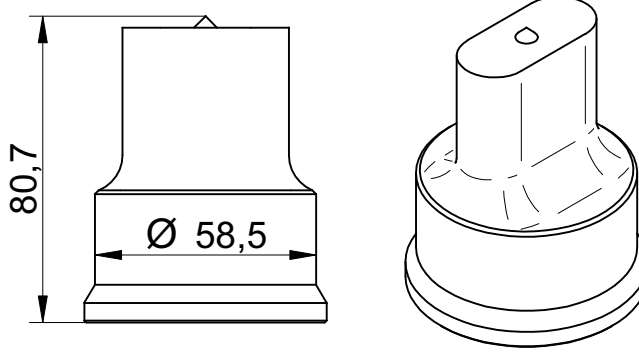
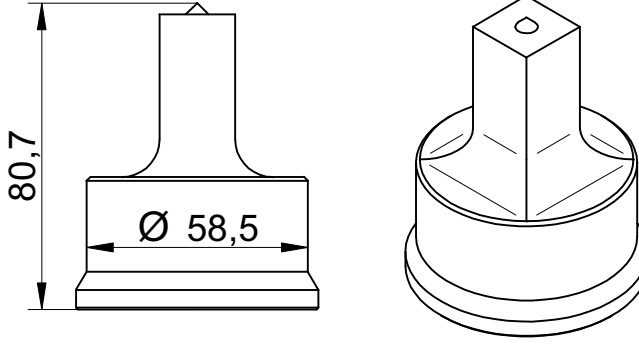
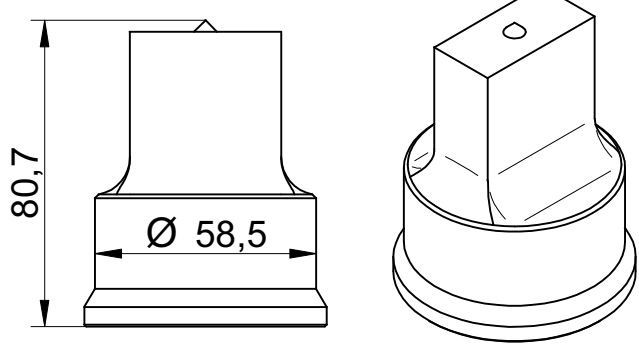
	<p>Round punch \varnothing(mm)</p> <p>20,0 ÷ 50,5 Size at 0,5 mm</p>	<p>NR 7</p> <p>C</p>														
	<p>Oval punch (mm)</p> <p>5,5x58,5 ÷ 50x58,5 Size at 0,5 mm</p>	<p>NR 7</p> <p>C</p>														
	<p>Square punch (mm)</p> <p>20,0 ÷ 41,0 Size at 1 mm</p>	<p>NR 7</p> <p>C</p>														
	<p>Rectangular punch (mm)</p> <table border="1" data-bbox="885 1720 1284 1933"> <tbody> <tr> <td>8x9÷8x56</td> <td>15x16÷15x50</td> </tr> <tr> <td>9x10÷9x50</td> <td>16x17÷16x50</td> </tr> <tr> <td>10x11÷10x50</td> <td>17x18÷17x50</td> </tr> <tr> <td>11x12÷11x50</td> <td>18x19÷18x50</td> </tr> <tr> <td>12x13÷12x50</td> <td>19x20÷20x50</td> </tr> <tr> <td>13x14÷13x50</td> <td>24x25÷24x50</td> </tr> <tr> <td>14x15÷14x50</td> <td>35x36÷35x44</td> </tr> </tbody> </table>	8x9÷8x56	15x16÷15x50	9x10÷9x50	16x17÷16x50	10x11÷10x50	17x18÷17x50	11x12÷11x50	18x19÷18x50	12x13÷12x50	19x20÷20x50	13x14÷13x50	24x25÷24x50	14x15÷14x50	35x36÷35x44	<p>NR 7</p> <p>C</p>
8x9÷8x56	15x16÷15x50															
9x10÷9x50	16x17÷16x50															
10x11÷10x50	17x18÷17x50															
11x12÷11x50	18x19÷18x50															
12x13÷12x50	19x20÷20x50															
13x14÷13x50	24x25÷24x50															
14x15÷14x50	35x36÷35x44															

	<p>Round punch \varnothing(mm)</p> <p>40,0 ÷ 90,0 Size at 0,5 mm</p>	<p>NR 11</p> <p>C</p>														
	<p>Oval punch (mm)</p> <p>10,0x90,0 ÷ 80,0x90,0 Size at 0,5 mm</p>	<p>NR 11</p> <p>C</p>														
	<p>Square punch (mm)</p> <p>20,0 ÷ 64,0 Size at 1 mm</p>	<p>NR 11</p> <p>C</p>														
	<p>Rectangular punch (mm)</p> <table border="1"> <tbody> <tr> <td>8x9÷8x86</td> <td>15x16÷15x82</td> </tr> <tr> <td>9x10÷9x82</td> <td>16x17÷16x82</td> </tr> <tr> <td>10x11÷10x82</td> <td>17x18÷17x82</td> </tr> <tr> <td>11x12÷11x82</td> <td>18x19÷18x82</td> </tr> <tr> <td>12x13÷12x82</td> <td>19x20÷20x82</td> </tr> <tr> <td>13x14÷13x82</td> <td>24x25÷24x82</td> </tr> <tr> <td>14x15÷14x82</td> <td>35x36÷35x82</td> </tr> </tbody> </table>	8x9÷8x86	15x16÷15x82	9x10÷9x82	16x17÷16x82	10x11÷10x82	17x18÷17x82	11x12÷11x82	18x19÷18x82	12x13÷12x82	19x20÷20x82	13x14÷13x82	24x25÷24x82	14x15÷14x82	35x36÷35x82	<p>NR 11</p> <p>C</p>
8x9÷8x86	15x16÷15x82															
9x10÷9x82	16x17÷16x82															
10x11÷10x82	17x18÷17x82															
11x12÷11x82	18x19÷18x82															
12x13÷12x82	19x20÷20x82															
13x14÷13x82	24x25÷24x82															
14x15÷14x82	35x36÷35x82															

	<p>Rounding (mm)</p> <table border="1"> <tr><td>R 5</td><td>R 10</td><td>R 15</td></tr> <tr><td>R 6</td><td>R 11</td><td></td></tr> <tr><td>R 7</td><td>R 12</td><td></td></tr> <tr><td>R 8</td><td>R 13</td><td></td></tr> <tr><td>R 9</td><td>R 14</td><td></td></tr> </table>	R 5	R 10	R 15	R 6	R 11		R 7	R 12		R 8	R 13		R 9	R 14		<p>NR 3</p> <p>C</p>
R 5	R 10	R 15															
R 6	R 11																
R 7	R 12																
R 8	R 13																
R 9	R 14																
	<p>Rounding (mm)</p> <table border="1"> <tr><td>R 5</td><td>R 10</td><td>R 15</td></tr> <tr><td>R 6</td><td>R 11</td><td></td></tr> <tr><td>R 7</td><td>R 12</td><td></td></tr> <tr><td>R 8</td><td>R 13</td><td></td></tr> <tr><td>R 9</td><td>R 14</td><td></td></tr> </table>	R 5	R 10	R 15	R 6	R 11		R 7	R 12		R 8	R 13		R 9	R 14		<p>NR 4</p> <p>A</p>
R 5	R 10	R 15															
R 6	R 11																
R 7	R 12																
R 8	R 13																
R 9	R 14																
	<p>Rounding (mm)</p> <table border="1"> <tr><td>R 5</td><td>R 10</td><td>R 15</td></tr> <tr><td>R 6</td><td>R 11</td><td></td></tr> <tr><td>R 7</td><td>R 12</td><td></td></tr> <tr><td>R 8</td><td>R 13</td><td></td></tr> <tr><td>R 9</td><td>R 14</td><td></td></tr> </table>	R 5	R 10	R 15	R 6	R 11		R 7	R 12		R 8	R 13		R 9	R 14		<p>NR 5</p> <p>B</p>
R 5	R 10	R 15															
R 6	R 11																
R 7	R 12																
R 8	R 13																
R 9	R 14																
	<p>Rounding (mm)</p> <table border="1"> <tr><td>R 5</td><td>R 10</td><td>R 15</td></tr> <tr><td>R 6</td><td>R 11</td><td></td></tr> <tr><td>R 7</td><td>R 12</td><td></td></tr> <tr><td>R 8</td><td>R 13</td><td></td></tr> <tr><td>R 9</td><td>R 14</td><td></td></tr> </table>	R 5	R 10	R 15	R 6	R 11		R 7	R 12		R 8	R 13		R 9	R 14		<p>NR 6</p> <p>C</p>
R 5	R 10	R 15															
R 6	R 11																
R 7	R 12																
R 8	R 13																
R 9	R 14																
	<p>Rounding (mm)</p> <table border="1"> <tr><td colspan="3">R 10 ÷ R 35</td></tr> <tr><td colspan="3">Size at 1 mm</td></tr> </table>	R 10 ÷ R 35			Size at 1 mm			<p>NR 7</p> <p>C</p>									
R 10 ÷ R 35																	
Size at 1 mm																	

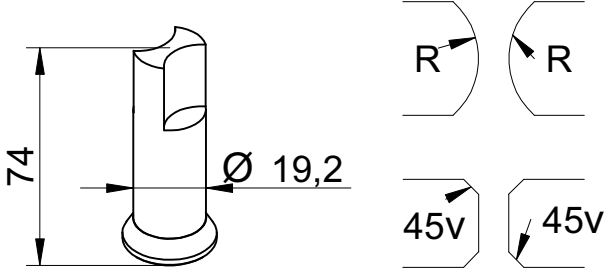
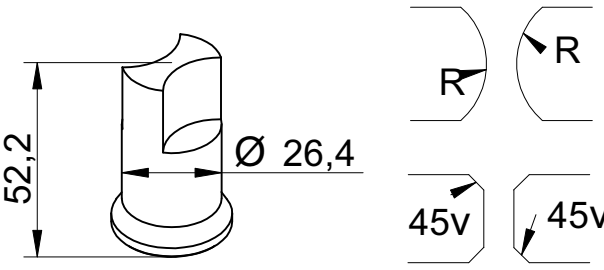
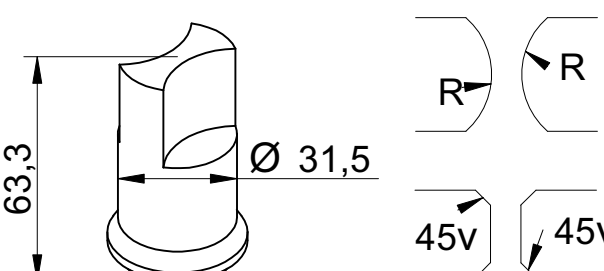
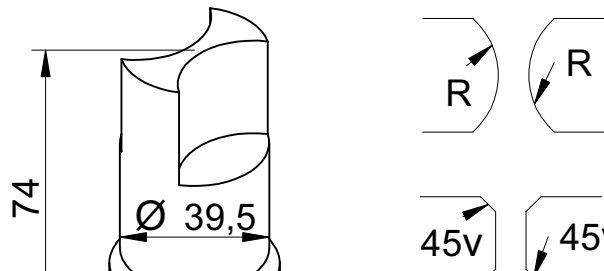
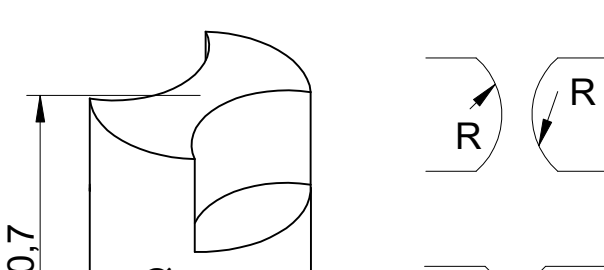
	<p>Cutting and rounding (mm)</p> <p>R 5 R 10</p> <p>R 6</p> <p>R 7</p> <p>R 8</p> <p>R 9</p>	<p>NR 3</p> <p>C</p>
	<p>Cutting and rounding (mm)</p> <p>R 5 R 10 R 15</p> <p>R 6 R 11</p> <p>R 7 R 12</p> <p>R 8 R 13</p> <p>R 9 R 14</p>	<p>NR 4</p> <p>A</p>
	<p>Cutting and rounding (mm)</p> <p>R 5 R 10 R 15</p> <p>R 6 R 11</p> <p>R 7 R 12</p> <p>R 8 R 13</p> <p>R 9 R 14</p>	<p>NR 5</p> <p>B</p>
	<p>Cutting and rounding (mm)</p> <p>R 5 R 10 R 16</p> <p>R 6 R 11 R 17</p> <p>R 7 R 12 R 18</p> <p>R 8 R 13 R 19</p> <p>R 9 R 14 R 20</p> <p>R 10 R 15</p>	<p>NR 6</p> <p>C</p>
	<p>Cutting and rounding (mm)</p> <p>R 5 R 10 R 16 R 22</p> <p>R 6 R 11 R 17 R 23</p> <p>R 7 R 12 R 18 R 24</p> <p>R 8 R 13 R 19 R 25</p> <p>R 9 R 14 R 20 R 26</p> <p>R 10 R 15 R 21 R 27</p>	<p>NR 7</p> <p>C</p>

	<p>Round dies \varnothing(mm)</p> <p>3,2 ÷ 31,2 Wielkość co 0,5 mm</p>	<p>NR 2</p> <p>A</p>
	<p>Oval dies (mm)</p> <p>5,2x10,2 ÷ 22,7x30,7 Wielkość co 0,5 mm</p>	<p>NR 2</p> <p>A</p>
	<p>Square dies (mm)</p> <p>4,2 ÷ 20,7 Wielkość co 0,5 mm</p>	<p>NR 2</p> <p>A</p>
	<p>Rectangular dies (mm)</p> <p>8,2x9,2 ÷ 20,2x24,2 8,7x9,7 ÷ 20,7x24,7 Wielkość co 0,5 mm</p>	<p>NR 2</p> <p>A</p>
	<p>Dies eccentric \varnothing (mm)</p> <p>5,2 ÷ 18,7 Wielkość co 0,5 mm</p>	<p>NR 13</p> <p>A</p>

	<p>Round dies \varnothing(mm)</p> <p>3,2 ÷ 33,2 Wielkość co 0,5 mm</p>	<p>NR 3</p>
	<p>Oval dies (mm)</p> <p>5,2x10,2 ÷ 22,7x31,7 Wielkość co 0,5 mm</p>	<p>NR 3</p> <p>B</p>
	<p>Square dies (mm)</p> <p>4,2 ÷ 22,7 Wielkość co 0,5 mm</p>	<p>NR 3</p> <p>B</p>
	<p>Rectangular dies (mm)</p> <p>8,2x9,2 ÷ 20,2x30,2 8,7x9,7 ÷ 20,7x30,7 Wielkość co 0,5 mm</p>	<p>NR 3</p> <p>B</p>
	<p>Dies eccentric \varnothing (mm)</p> <p>5,7 ÷ 24,7 Wielkość co 0,5 mm</p>	<p>NR 14</p> <p>B</p>

	<p>Round dies \varnothing(mm)</p> <p>3,2 ÷ 40,7 Wielkość co 0,5 mm</p>	<p>NR 4</p> <p>C</p>
	<p>Oval dies (mm)</p> <p>5,2x10,2 ÷ 22,7x31,7 Wielkość co 0,5 mm</p>	<p>NR 4</p> <p>C</p>
	<p>Square dies (mm)</p> <p>4,2 ÷ 28,7 Wielkość co 0,5 mm</p>	<p>NR 4</p> <p>C</p>
	<p>Rectangular dies (mm)</p> <p>8,2x9,2 ÷ 20,2x45,2 8,7x9,7 ÷ 20,7x45,7 Wielkość co 0,5 mm</p>	<p>NR 4</p> <p>C</p>

	<p>Round dies \varnothing(mm)</p> <p>40,2 ÷ 65,7 Wielkość co 0,5 mm</p>	<p>NR 6</p> <p>C</p>
	<p>Oval dies (mm)</p> <p>5,2x10,2 ÷ 22,7x55,7 Wielkość co 0,5 mm</p>	<p>NR 6</p> <p>C</p>
	<p>Square dies (mm)</p> <p>4,2 ÷ 40,7 Wielkość co 0,5 mm</p>	<p>NR 6</p> <p>C</p>
	<p>Rectangular dies (mm)</p> <p>8,2x9,2 ÷ 20,2x65,2 8,7x9,7 ÷ 20,7x65,7 Wielkość co 0,5 mm</p>	<p>NR 6</p> <p>C</p>

	<p>Round dies \varnothing(mm)</p> <p>40,2 ÷ 100,7 Wielkość co 0,5 mm</p>	<p>NR 20</p> <p>C</p>
	<p>Oval dies (mm)</p> <p>5,2x10,2 ÷ 80,7x90,7 Wielkość co 0,5 mm</p>	<p>NR 20</p> <p>C</p>
	<p>Square dies (mm)</p> <p>4,2 ÷ 64,7 Wielkość co 0,5 mm</p>	<p>NR 20</p> <p>C</p>
	<p>Rectangular dies (mm)</p> <p>8,2x9,2 ÷ 35,2x82,2 8,7x9,7 ÷ 35,7x82,7 Wielkość co 0,5 mm</p>	<p>NR 20</p> <p>C</p>

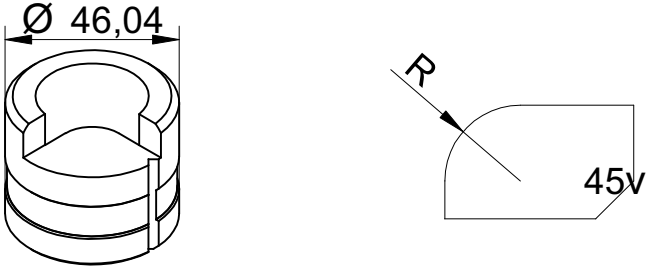
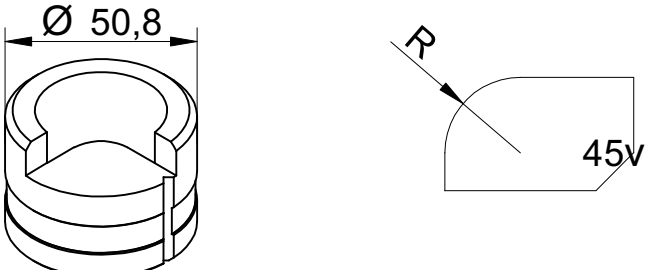
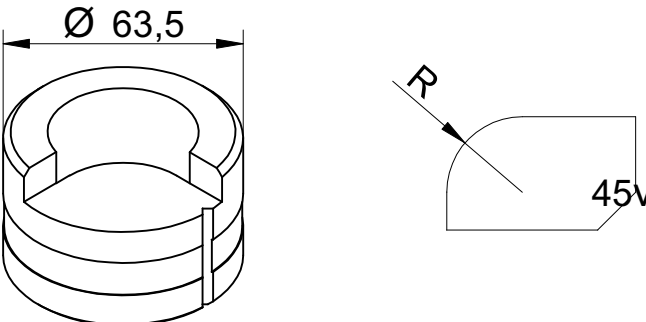
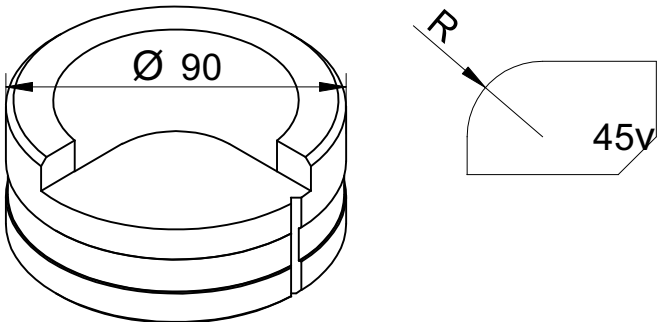
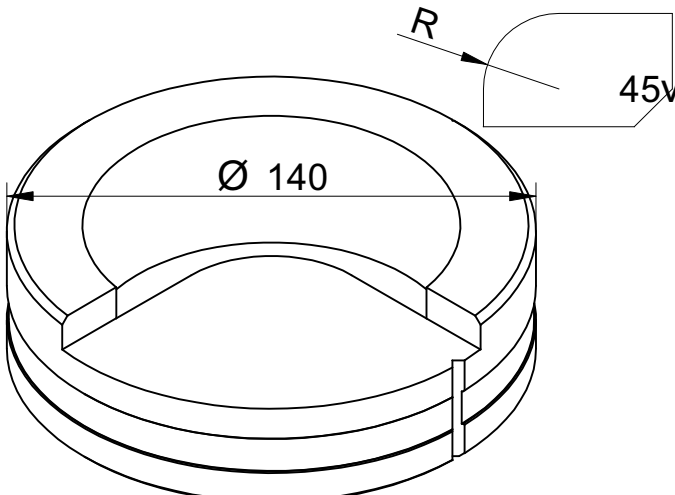
	<p>Rounding (mm)</p> <table border="1"> <tr><td>R 5</td><td>R 10</td><td>R 15</td></tr> <tr><td>R 6</td><td>R 11</td><td></td></tr> <tr><td>R 7</td><td>R 12</td><td></td></tr> <tr><td>R 8</td><td>R 13</td><td></td></tr> <tr><td>R 9</td><td>R 14</td><td></td></tr> </table>	R 5	R 10	R 15	R 6	R 11		R 7	R 12		R 8	R 13		R 9	R 14		<p>NR 2</p>						
R 5	R 10	R 15																					
R 6	R 11																						
R 7	R 12																						
R 8	R 13																						
R 9	R 14																						
	<p>Rounding (mm)</p> <table border="1"> <tr><td>R 5</td><td>R 10</td><td>R 15</td></tr> <tr><td>R 6</td><td>R 11</td><td></td></tr> <tr><td>R 7</td><td>R 12</td><td></td></tr> <tr><td>R 8</td><td>R 13</td><td></td></tr> <tr><td>R 9</td><td>R 14</td><td></td></tr> </table>	R 5	R 10	R 15	R 6	R 11		R 7	R 12		R 8	R 13		R 9	R 14		<p>NR 3</p>						
R 5	R 10	R 15																					
R 6	R 11																						
R 7	R 12																						
R 8	R 13																						
R 9	R 14																						
	<p>Rounding (mm)</p> <table border="1"> <tr><td>R 5</td><td>R 10</td><td>R 15</td></tr> <tr><td>R 6</td><td>R 11</td><td>R 20</td></tr> <tr><td>R 7</td><td>R 12</td><td></td></tr> <tr><td>R 8</td><td>R 13</td><td></td></tr> <tr><td>R 9</td><td>R 14</td><td></td></tr> </table>	R 5	R 10	R 15	R 6	R 11	R 20	R 7	R 12		R 8	R 13		R 9	R 14		<p>NR 4</p>						
R 5	R 10	R 15																					
R 6	R 11	R 20																					
R 7	R 12																						
R 8	R 13																						
R 9	R 14																						
	<p>Rounding (mm)</p> <table border="1"> <tr><td>R 10</td><td>R 17</td><td>R 24</td></tr> <tr><td>R 11</td><td>R 18</td><td>R 25</td></tr> <tr><td>R 12</td><td>R 19</td><td>R 26</td></tr> <tr><td>R 13</td><td>R 20</td><td>R 27</td></tr> <tr><td>R 14</td><td>R 21</td><td>R 28</td></tr> <tr><td>R 15</td><td>R 22</td><td>R 29</td></tr> <tr><td>R 16</td><td>R 23</td><td>R 30</td></tr> </table>	R 10	R 17	R 24	R 11	R 18	R 25	R 12	R 19	R 26	R 13	R 20	R 27	R 14	R 21	R 28	R 15	R 22	R 29	R 16	R 23	R 30	<p>NR 6</p>
R 10	R 17	R 24																					
R 11	R 18	R 25																					
R 12	R 19	R 26																					
R 13	R 20	R 27																					
R 14	R 21	R 28																					
R 15	R 22	R 29																					
R 16	R 23	R 30																					
	<p>Rounding (mm)</p> <p>R 10 ÷ R 35 Size at 1 mm</p> <p>Special execution</p>	<p>NR 20</p>																					

<p>Ø 46,04</p> <p>R</p> <p>45v</p>	<p>Cutting and rounding (mm)</p> <p>R 5 R 10</p> <p>R 6</p> <p>R 7</p> <p>R 8</p> <p>R 9</p>	<p>NR 2</p> <p>A</p>
<p>Ø 50,8</p> <p>R</p> <p>45v</p>	<p>Cutting and rounding (mm)</p> <p>R 5 R 10 R 15</p> <p>R 6 R 11</p> <p>R 7 R 12</p> <p>R 8 R 13</p> <p>R 9 R 14</p>	<p>NR 3</p> <p>B</p>
<p>Ø 63,5</p> <p>R</p> <p>45v</p>	<p>Cutting and rounding (mm)</p> <p>R 5 R 10 R 15</p> <p>R 6 R 11</p> <p>R 7 R 12</p> <p>R 8 R 13</p> <p>R 9 R 14</p>	<p>NR 4</p> <p>C</p>
<p>Ø 90</p> <p>R</p> <p>45v</p>	<p>Cutting and rounding (mm)</p> <p>R 5 R 10 R 16</p> <p>R 6 R 11 R 17</p> <p>R 7 R 12 R 18</p> <p>R 8 R 13 R 19</p> <p>R 9 R 14 R 20</p> <p>R 10 R 15</p>	<p>NR 6</p> <p>C</p>
<p>Ø 140</p> <p>R</p> <p>45v</p>	<p>Cutting and rounding (mm)</p> <p>R 5 R 10 R 16 R 22</p> <p>R 6 R 11 R 17 R 23</p> <p>R 7 R 12 R 18 R 24</p> <p>R 8 R 13 R 19 R 25</p> <p>R 9 R 14 R 20 R 26</p> <p>R 10 R 15 R 21 R 27</p> <p>Special execution</p>	<p>NR 20</p> <p>C</p>

Special tools

You can perform punches and dies with special dimensions, with individual bulk. Execution based on a sketch or drawing.

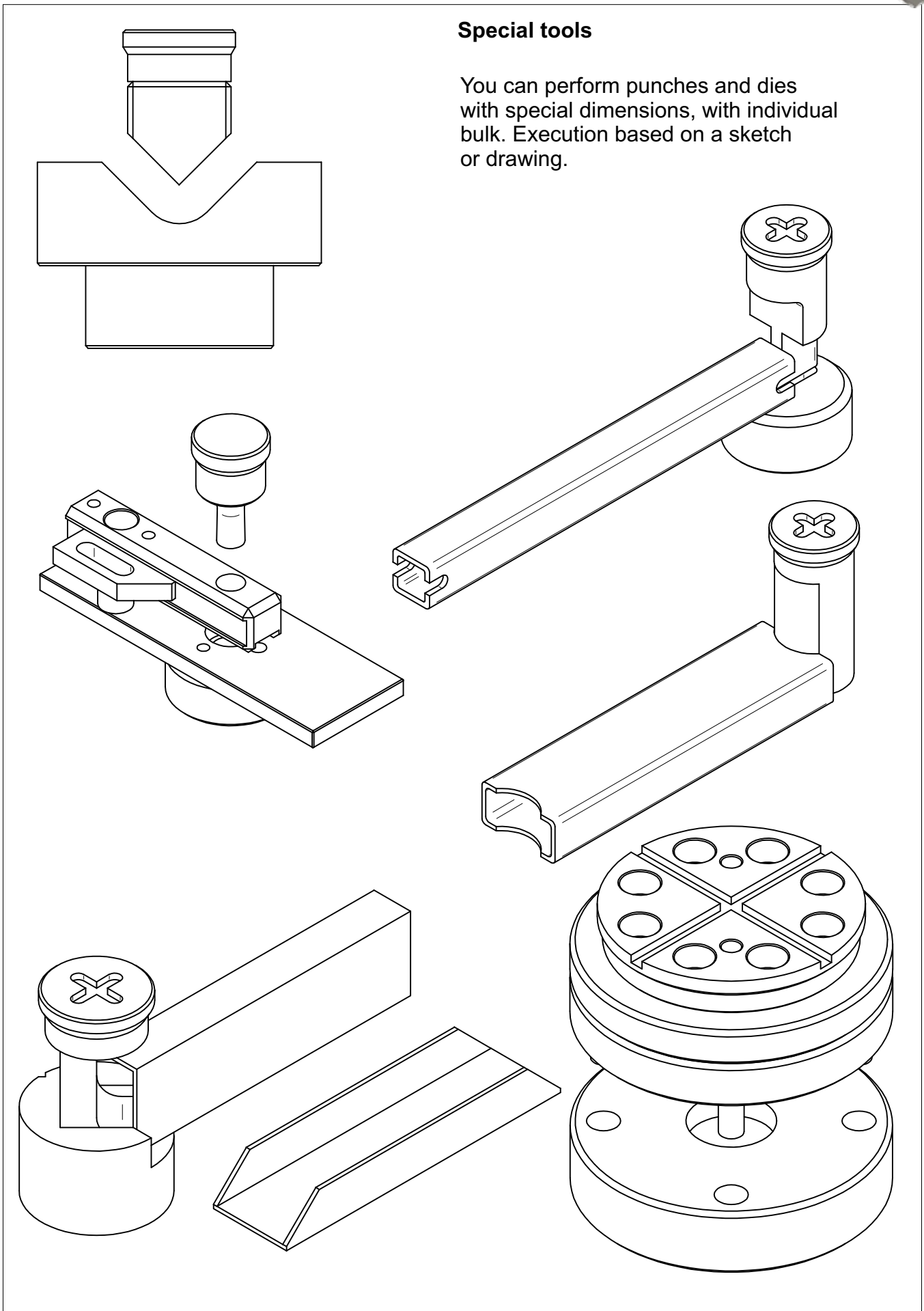

Special tools

You can perform punches and dies with special dimensions, with individual bulk. Execution based on a sketch or drawing.

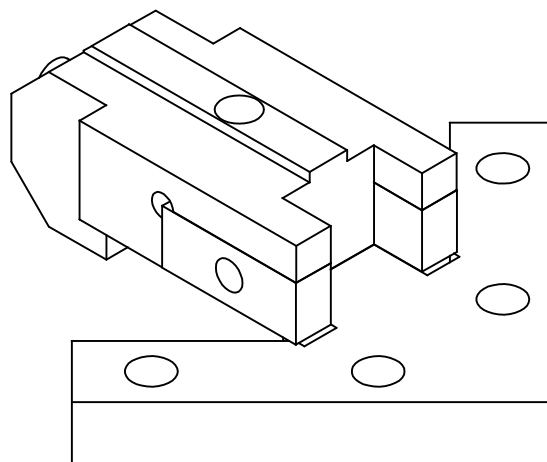
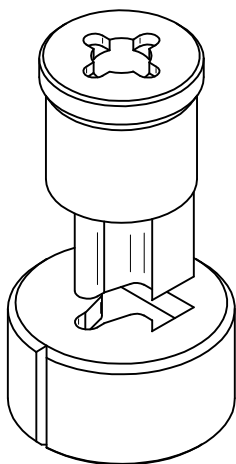
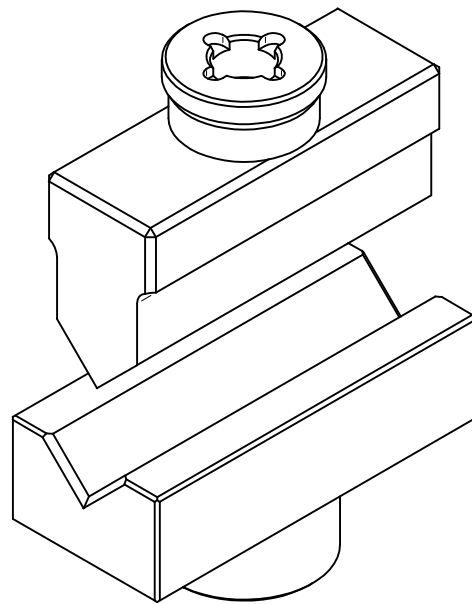
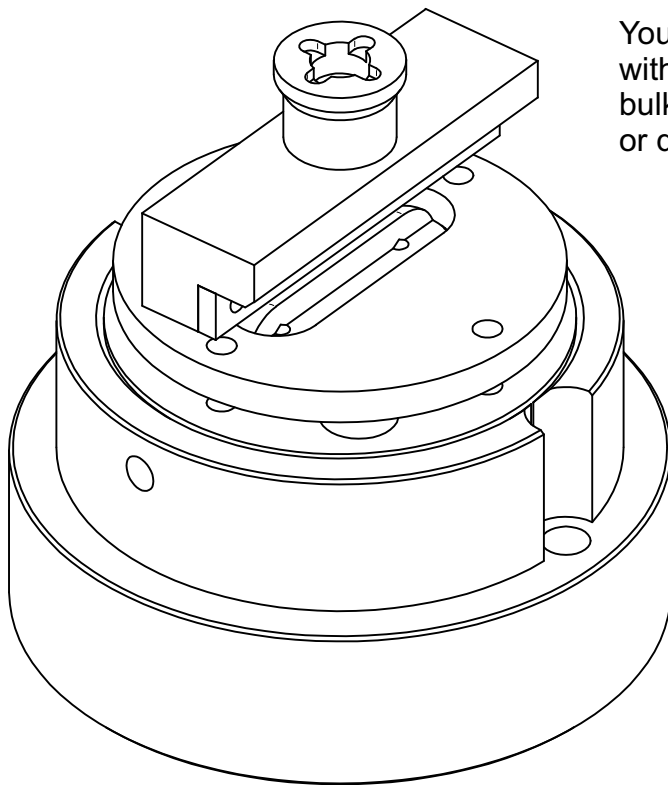

Special tools

You can perform punches and dies with special dimensions, with individual bulk. Execution based on a sketch or drawing.

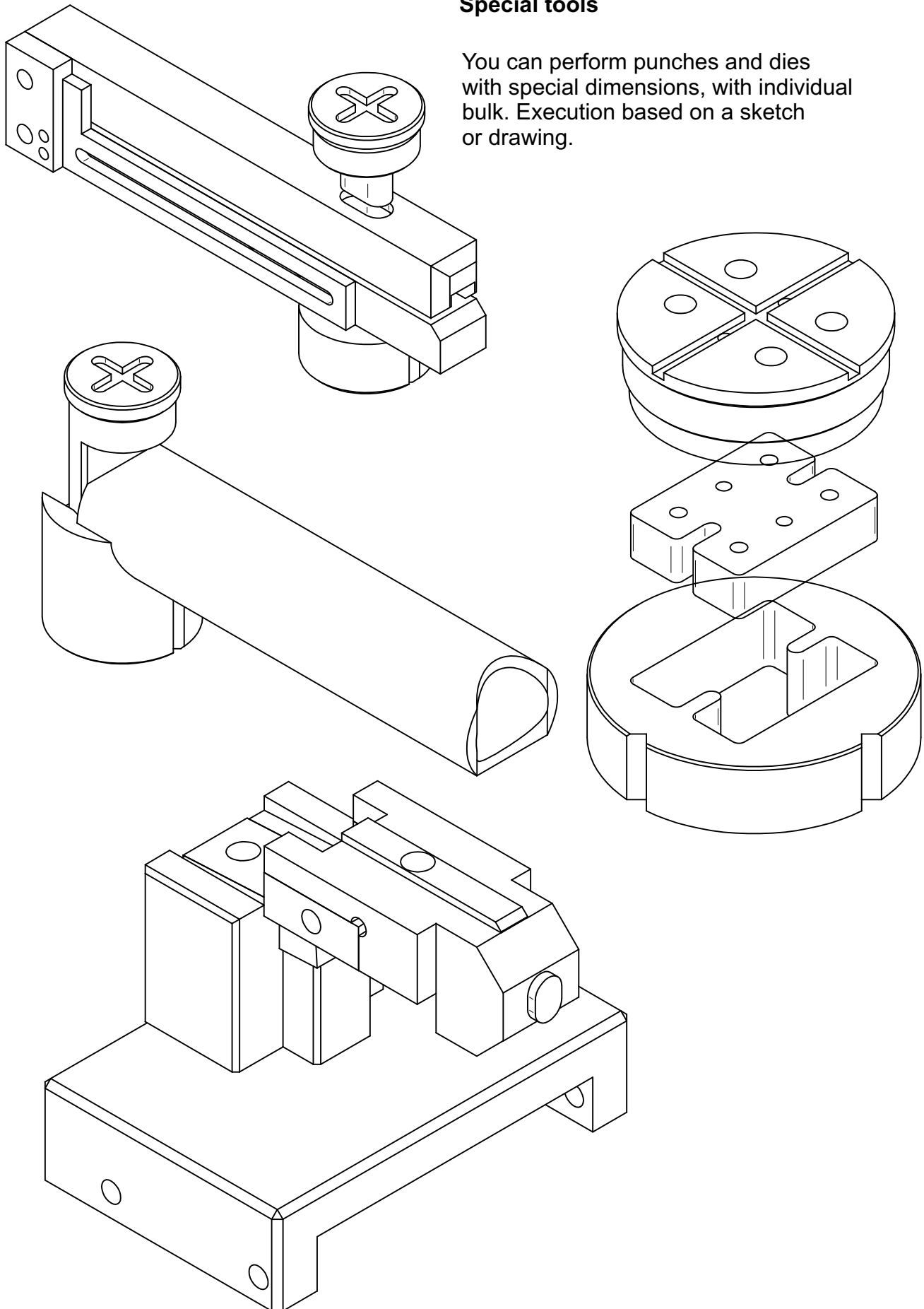



DESIGN AND CONSTRUCTION :

- PUNCHES • TRIMMER • PUNCHES AND DIES FOR PUMPING
- PUNCHES AND DIES FOR CUTTING • CNC
- ENGRAVING • TECHNICAL HEAT TREATMENT



WROMET Sp. z o.o.
ul. Kaczeńcowa 2
62-510 Konin

tel. +48 63 245 80 01
info@wromet.com.pl

NIP PL 665-294-89-81
KRS: 000362355