

STEMPLE, MATRYCE
DO MASZYN MUBEA



wromet.com.pl

Narzędzia do maszyn MUBEA

Modell	
KBL 11 N ab Ser.Nr. 3534 Optima 11, 4520, 560, 600	HPSN 450
KBL 13 ab Ser.Nr. 1790 Optima 13,6530,750	HPSN 600
KBL 16 ab Ser.Nr. 2599 Optima 16, 8040	HPSN 350
KBL Optima 900	HPSN 500
KBL 20 ab Ser.Nr. 2708 Optima 20, 100050, 1100	HPSN 750
KBL 25 ab Ser.Nr. 9821 Optima 25, 13070, 1300	HIW 450
KLS 1100	HIW 600
KL 10, KL 30, KL 350	HIW 1000
KL 11, KL OPTIMA 45, KL OPTIMA 560	KLSH 550
KL 13, KL OPTIMA 65, KL OPTIMA 560	KLSH 900 KLSH 1100/KBLH 1000, HP 1000/760
KL 16, KL OPTIMA 80	KLH 300/610 + KLH 500/610
KL OPTIMA 900	KLH 700/760
KL 20, KL OPTIMA 100, KL OPTIMA 1100	500 KBLH 300, KBLH
KL 25, KL OPTIMA 130, KL OPTIMA 1300	KBLH 700
KL 100	HIW 550
KL 160	HIW 750
BF 10, BF 2012, BF 350	HIW 1000 ab Baujahr 1987
BFL 35, BFL 350, BFLH 400	MIW 400
HP 350/600	MIW 600
HP 450/760	MIW 800
HPS 250	PROFI 500
HPS 350, HPS 350 E	

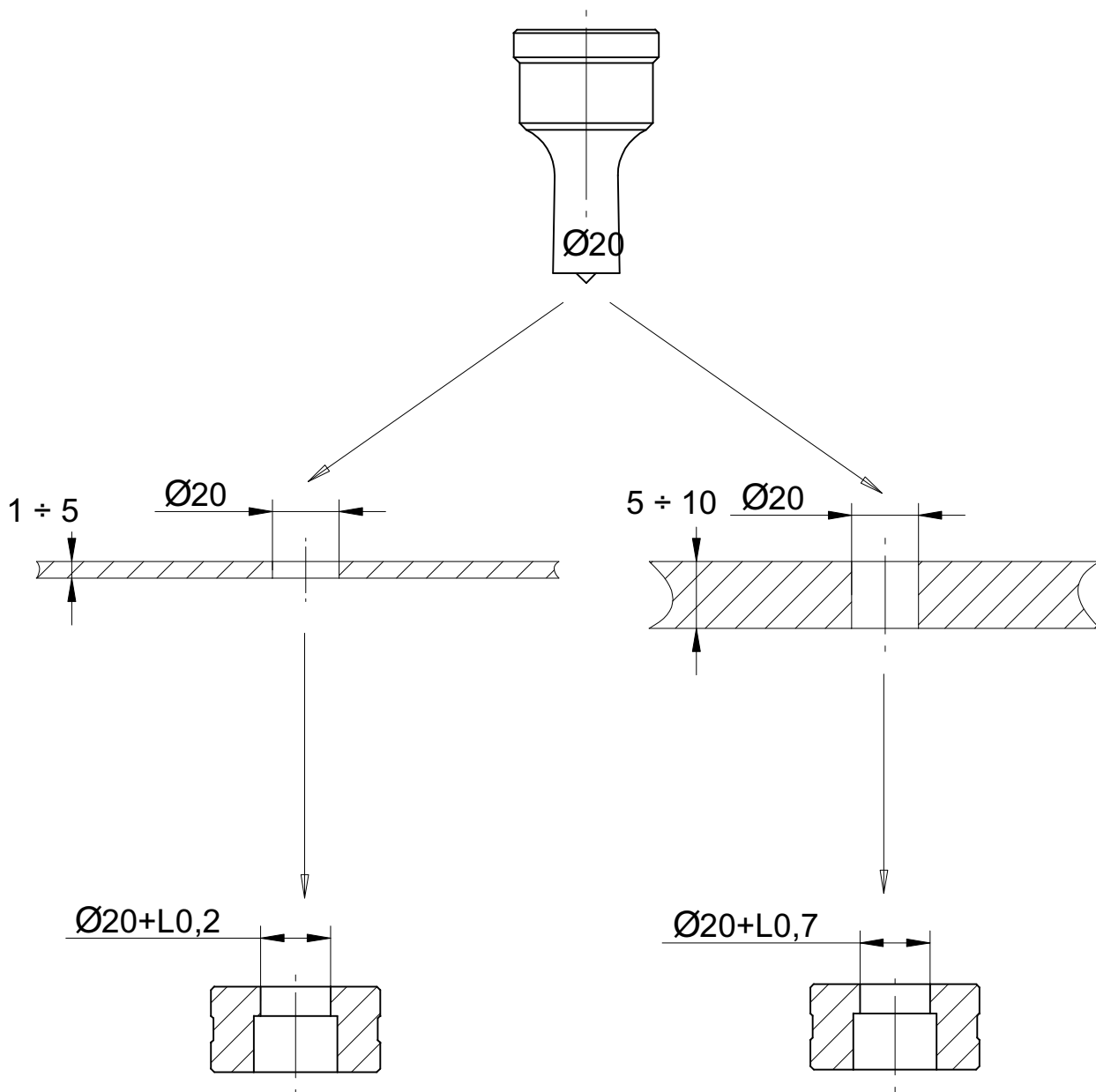

Stempel określa wymiar wykrojonego otworu.
Otwór w matrycy odpowiada rozmiarowi stempla + luz
Dla cienkich blach produkujemy 0,2 mm, dla grubych blach 0,7 mm.
Istnieje możliwość wykonania stempla i matrycy o specjalnych wymiarach i z indywidualnym luzem.

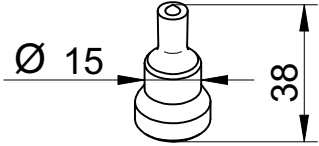
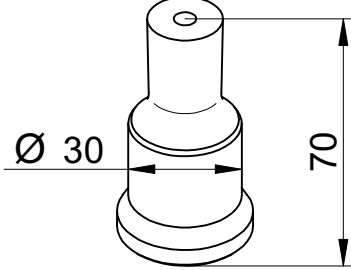
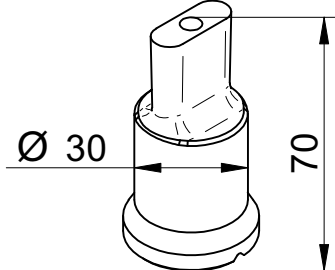
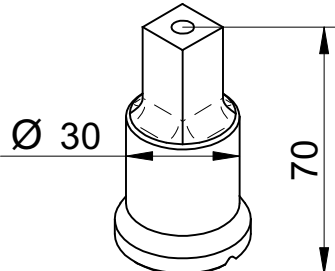
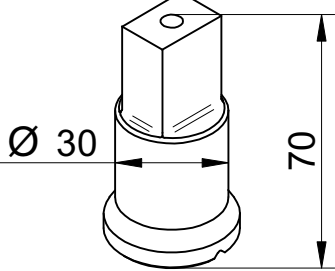
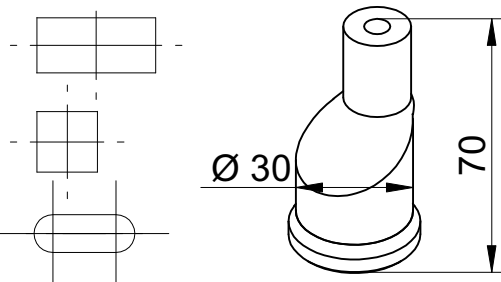

	<p>Stempel okrągły \varnothing (mm)</p> <p>3,0 ÷ 15,0 Wielkość co 0,5 mm</p>	<p>NR 1</p>
	<p>Stempel okrągły \varnothing (mm)</p> <p>3,0 ÷ 30,0 Wielkość co 0,5 mm</p>	<p>NR 2</p>
	<p>Stempel owalny (mm)</p> <p>5,5x10 ÷ 22,0x30,0 Wielkość co 0,5 mm</p>	<p>NR 2</p>
	<p>Stempel kwadrat (mm)</p> <p>4,0 ÷ 21,0 Wielkość co 0,5 mm</p>	<p>NR 2</p>
	<p>Stempel prostokąt (mm)</p> <p>8x9÷8x28 15x16÷15x20 9x10÷9x35 10x11÷10x20 11x12÷11x20 12x13÷12x20 13x14÷13x20 14x15÷14x20</p>	<p>NR 2</p>
	<p>Stempel niecentryczny \varnothing (mm)</p> <p>3,0 ÷ 15,0 Wielkość co 0,5 mm</p>	<p>NR 2</p>

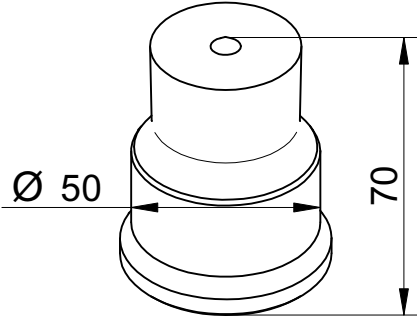
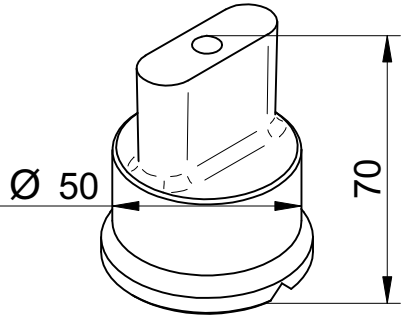
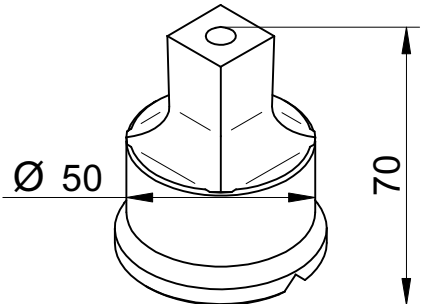
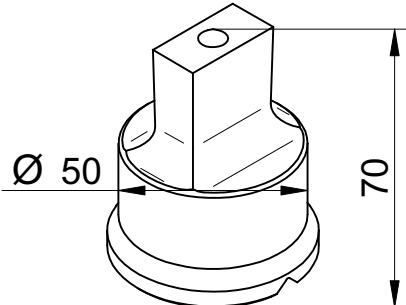
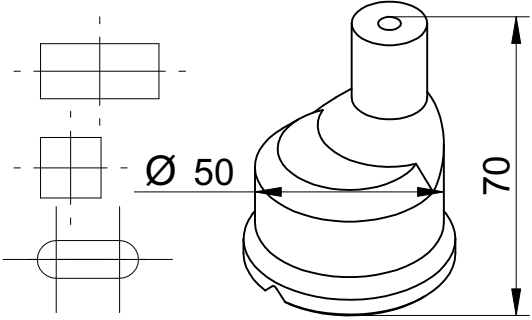
	<p>Stempel okrągły \varnothing (mm)</p> <p>3,0 ÷ 30,0 Wielkość co 0,5 mm</p>	<p>NR 3</p>														
	<p>Stempel owalny (mm)</p> <p>5,5x10 ÷ 27,0x40,0 Wielkość co 0,5 mm</p>	<p>NR 3</p>														
	<p>Stempel kwadrat (mm)</p> <p>4,0 ÷ 28,0 Wielkość co 0,5 mm</p>	<p>NR 3</p>														
	<p>Stempel prostokąt (mm)</p> <table border="0"> <tbody> <tr> <td>8x9÷8x35</td> <td>15x16÷15x30</td> </tr> <tr> <td>9x10÷9x35</td> <td>16x17÷16x30</td> </tr> <tr> <td>10x11÷10x30</td> <td>17x18÷17x30</td> </tr> <tr> <td>11x12÷11x30</td> <td>18x19÷18x30</td> </tr> <tr> <td>12x13÷12x30</td> <td>19x20÷20x30</td> </tr> <tr> <td>13x14÷13x30</td> <td>24x25÷24x30</td> </tr> <tr> <td>14x15÷14x30</td> <td></td> </tr> </tbody> </table>	8x9÷8x35	15x16÷15x30	9x10÷9x35	16x17÷16x30	10x11÷10x30	17x18÷17x30	11x12÷11x30	18x19÷18x30	12x13÷12x30	19x20÷20x30	13x14÷13x30	24x25÷24x30	14x15÷14x30		<p>NR 3</p>
8x9÷8x35	15x16÷15x30															
9x10÷9x35	16x17÷16x30															
10x11÷10x30	17x18÷17x30															
11x12÷11x30	18x19÷18x30															
12x13÷12x30	19x20÷20x30															
13x14÷13x30	24x25÷24x30															
14x15÷14x30																
	<p>Stempel niecentryczny \varnothing (mm)</p> <p>3,0 ÷ 20,0 Wielkość co 0,5 mm</p>	<p>NR 3</p>														

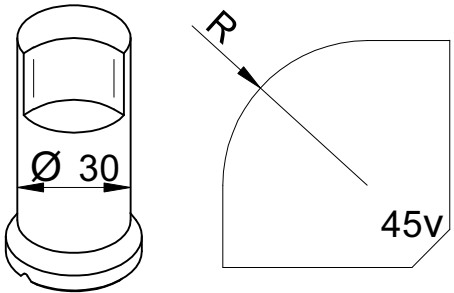
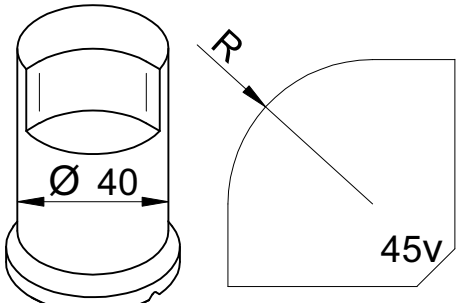
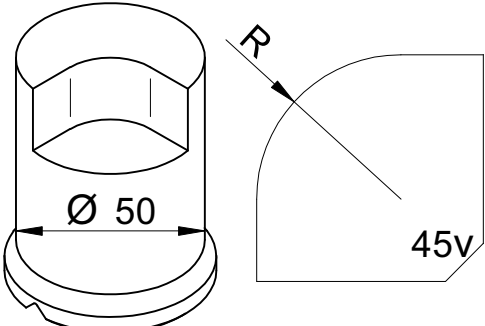
	<p>Stempel okrągły \varnothing (mm)</p> <p>3,0 ÷ 50,0 Wielkość co 0,5 mm</p>	<p>NR 4</p>														
	<p>Stempel owalny (mm)</p> <p>5,5x10 ÷ 27,0x50,0 Wielkość co 0,5 mm</p>	<p>NR 4</p>														
	<p>Stempel kwadrat (mm)</p> <p>4,0 ÷ 28,0 Wielkość co 0,5 mm</p>	<p>NR 4</p>														
	<p>Stempel prostokąt (mm)</p> <table border="1" data-bbox="746 1402 1150 1615"> <tbody> <tr> <td>8x9÷8x48</td> <td>15x16÷15x42</td> </tr> <tr> <td>9x10÷9x50</td> <td>16x17÷16x42</td> </tr> <tr> <td>10x11÷10x42</td> <td>17x18÷17x42</td> </tr> <tr> <td>11x12÷11x42</td> <td>18x19÷18x42</td> </tr> <tr> <td>12x13÷12x42</td> <td>19x20÷20x42</td> </tr> <tr> <td>13x14÷13x42</td> <td>24x25÷24x42</td> </tr> <tr> <td>14x15÷14x42</td> <td>30x31÷30x39</td> </tr> </tbody> </table>	8x9÷8x48	15x16÷15x42	9x10÷9x50	16x17÷16x42	10x11÷10x42	17x18÷17x42	11x12÷11x42	18x19÷18x42	12x13÷12x42	19x20÷20x42	13x14÷13x42	24x25÷24x42	14x15÷14x42	30x31÷30x39	<p>NR 4</p>
8x9÷8x48	15x16÷15x42															
9x10÷9x50	16x17÷16x42															
10x11÷10x42	17x18÷17x42															
11x12÷11x42	18x19÷18x42															
12x13÷12x42	19x20÷20x42															
13x14÷13x42	24x25÷24x42															
14x15÷14x42	30x31÷30x39															
	<p>Stempel niecentryczny \varnothing (mm)</p> <p>3,0 ÷ 25,0 Wielkość co 0,5 mm</p>	<p>NR 4</p>														

	<p>Zaokrąglanie (mm)</p> <table border="1"> <tbody> <tr><td>R 5</td><td>R 10</td><td>R 15</td></tr> <tr><td>R 6</td><td>R 11</td><td></td></tr> <tr><td>R 7</td><td>R 12</td><td></td></tr> <tr><td>R 8</td><td>R 13</td><td></td></tr> <tr><td>R 9</td><td>R 14</td><td></td></tr> </tbody> </table>	R 5	R 10	R 15	R 6	R 11		R 7	R 12		R 8	R 13		R 9	R 14		<p>NR 2</p>			
R 5	R 10	R 15																		
R 6	R 11																			
R 7	R 12																			
R 8	R 13																			
R 9	R 14																			
	<p>Zaokrąglanie (mm)</p> <table border="1"> <tbody> <tr><td>R 5</td><td>R 11</td><td>R 17</td></tr> <tr><td>R 6</td><td>R 12</td><td>R 18</td></tr> <tr><td>R 7</td><td>R 13</td><td>R 19</td></tr> <tr><td>R 8</td><td>R 14</td><td>R 20</td></tr> <tr><td>R 9</td><td>R 15</td><td></td></tr> <tr><td>R 10</td><td>R 16</td><td></td></tr> </tbody> </table>	R 5	R 11	R 17	R 6	R 12	R 18	R 7	R 13	R 19	R 8	R 14	R 20	R 9	R 15		R 10	R 16		<p>NR 3</p>
R 5	R 11	R 17																		
R 6	R 12	R 18																		
R 7	R 13	R 19																		
R 8	R 14	R 20																		
R 9	R 15																			
R 10	R 16																			
	<p>Zaokrąglanie (mm)</p> <table border="1"> <tbody> <tr><td>R 5</td><td>R 11</td><td>R 17</td></tr> <tr><td>R 6</td><td>R 12</td><td>R 18</td></tr> <tr><td>R 7</td><td>R 13</td><td>R 19</td></tr> <tr><td>R 8</td><td>R 14</td><td>R 20</td></tr> <tr><td>R 9</td><td>R 15</td><td>R 25</td></tr> <tr><td>R 10</td><td>R 16</td><td></td></tr> </tbody> </table>	R 5	R 11	R 17	R 6	R 12	R 18	R 7	R 13	R 19	R 8	R 14	R 20	R 9	R 15	R 25	R 10	R 16		<p>NR 4</p>
R 5	R 11	R 17																		
R 6	R 12	R 18																		
R 7	R 13	R 19																		
R 8	R 14	R 20																		
R 9	R 15	R 25																		
R 10	R 16																			

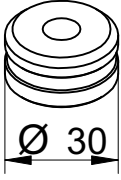
	<p>Rozcinanie i zaokrąglanie (mm)</p> <p>R 5 R 10</p> <p>R 6</p> <p>R 7</p> <p>R 8</p> <p>R 9</p>	<p>NR 2</p>
	<p>Rozcinanie i zaokrąglanie (mm)</p> <p>R 5 R 11</p> <p>R 6 R 12</p> <p>R 7</p> <p>R 8</p> <p>R 9</p> <p>R 10</p>	<p>NR 3</p>
	<p>Rozcinanie i zaokrąglanie (mm)</p> <p>R 5 R 11</p> <p>R 6 R 12</p> <p>R 7 R 13</p> <p>R 8 R 14</p> <p>R 9 R 15</p> <p>R 10</p>	<p>NR 4</p>

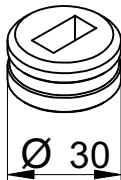
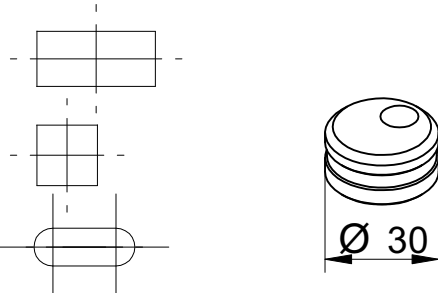
	<p>Matryca okrągła \varnothing (mm)</p> <p>3,2 ÷ 15,7 Wielkość co 0,5 mm</p>	<p>NR 30</p>
	<p>Matryca owalna (mm)</p> <p>5,3x10,3 ÷ 11,5x16,0 Wielkość co 0,5 mm</p>	<p>NR 30</p>
	<p>Matryca kwadrat (mm)</p> <p>4,2 ÷ 11,2 Wielkość co 0,5 mm</p>	<p>NR 30</p>
	<p>Matryca prostokąt (mm)</p> <p>8x9÷8x28 15x16÷15x20 9x10÷9x35 10x11÷10x20 11x12÷11x20 12x13÷12x20 13x14÷13x20 14x15÷14x20</p>	<p>NR 30</p>
	<p>Matryca niecentryczna \varnothing (mm)</p> <p>3,2 ÷ 15,7 Wielkość co 0,5 mm</p>	<p>NR 30</p>

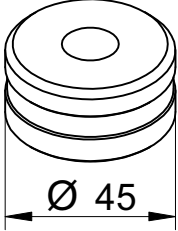
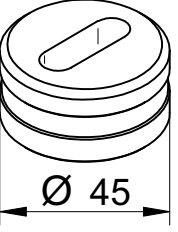
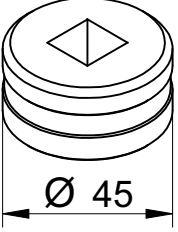
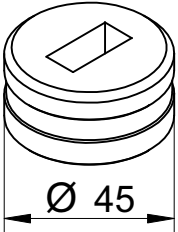
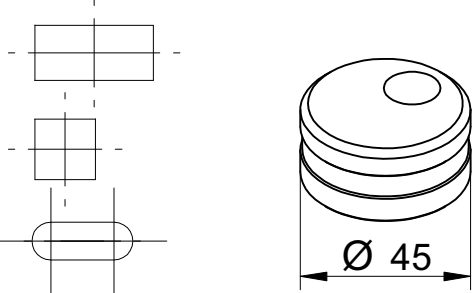
	<p>Matryca okrągła \varnothing (mm)</p> <p>3,2 ÷ 32,7 Wielkość co 0,5 mm</p>	<p>NR 45</p>
	<p>Matryca owalna (mm)</p> <p>5,3x20,3 ÷ 26,5x31,0 Wielkość co 0,5 mm</p>	<p>NR 45</p>
	<p>Matryca kwadrat (mm)</p> <p>4,2 ÷ 23,2 Wielkość co 0,5 mm</p>	<p>NR 45</p>
	<p>Matryca prostokąt (mm)</p> <p>8x9÷8x35 15x16÷15x30 9x10÷9x35 16x17÷16x30 10x11÷10x30 17x18÷17x30 11x12÷11x30 18x19÷18x30 12x13÷12x30 19x20÷20x30 13x14÷13x30 24x25÷24x30 14x15÷14x30</p>	<p>NR 45</p>
	<p>Matryca niecentryczna \varnothing (mm)</p> <p>3,2 ÷ 20,7 Wielkość co 0,5 mm</p>	<p>NR 45</p>

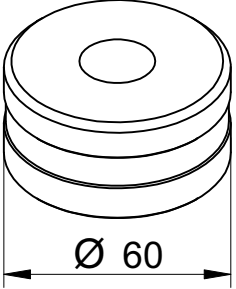
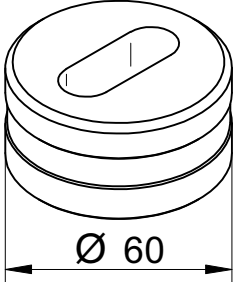
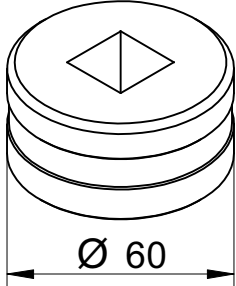
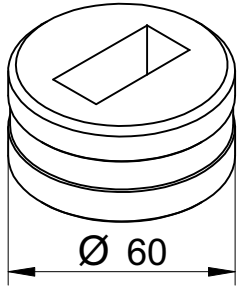
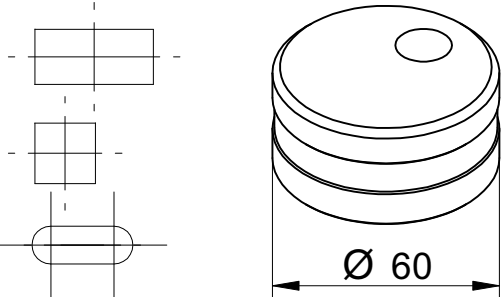
	<p>Matryca okrągła \varnothing (mm)</p> <p>3,2 ÷ 42,2 Wielkość co 0,5 mm</p>	<p>NR 60</p>														
	<p>Matryca owalna (mm)</p> <p>5,3x20,3 ÷ 28,0x41,0 Wielkość co 0,5 mm</p>	<p>NR 60</p>														
	<p>Matryca kwadrat (mm)</p> <p>4,2 ÷ 29,2 Wielkość co 0,5 mm</p>	<p>NR 60</p>														
	<p>Matryca prostokąt (mm)</p> <table border="0"> <tbody> <tr> <td>8x9÷8x48</td> <td>15x16÷15x42</td> </tr> <tr> <td>9x10÷9x50</td> <td>16x17÷16x42</td> </tr> <tr> <td>10x11÷10x42</td> <td>17x18÷17x42</td> </tr> <tr> <td>11x12÷11x42</td> <td>18x19÷18x42</td> </tr> <tr> <td>12x13÷12x42</td> <td>19x20÷20x42</td> </tr> <tr> <td>13x14÷13x42</td> <td>24x25÷24x42</td> </tr> <tr> <td>14x15÷14x42</td> <td>30x31÷30x39</td> </tr> </tbody> </table>	8x9÷8x48	15x16÷15x42	9x10÷9x50	16x17÷16x42	10x11÷10x42	17x18÷17x42	11x12÷11x42	18x19÷18x42	12x13÷12x42	19x20÷20x42	13x14÷13x42	24x25÷24x42	14x15÷14x42	30x31÷30x39	<p>NR 60</p>
8x9÷8x48	15x16÷15x42															
9x10÷9x50	16x17÷16x42															
10x11÷10x42	17x18÷17x42															
11x12÷11x42	18x19÷18x42															
12x13÷12x42	19x20÷20x42															
13x14÷13x42	24x25÷24x42															
14x15÷14x42	30x31÷30x39															
	<p>Matryca niecentryczna \varnothing (mm)</p> <p>3,2 ÷ 20,7 Wielkość co 0,5 mm</p>	<p>NR 60</p>														

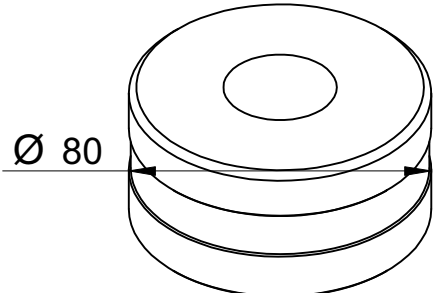
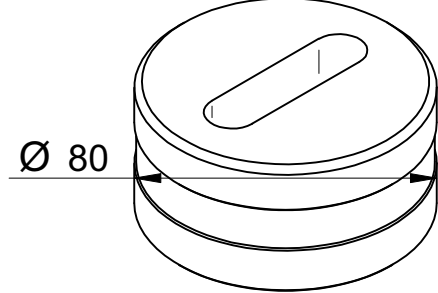
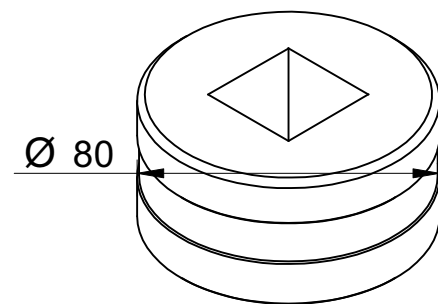
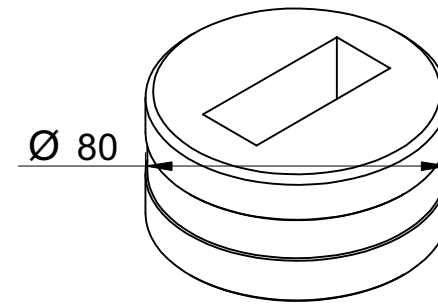
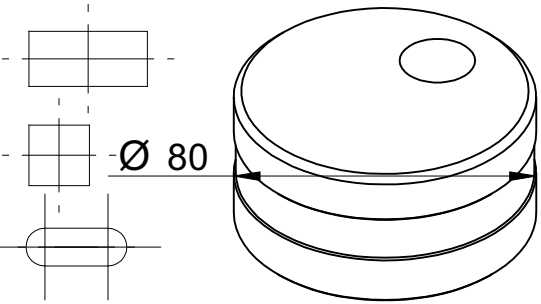
	<p>Matryca okrągła \varnothing (mm)</p> <p>3,2 ÷ 42,2 Wielkość co 0,5 mm</p>	<p>NR 80</p>														
	<p>Matryca owalna (mm)</p> <p>5,3x20,3 ÷ 28,0x41,0 Wielkość co 0,5 mm</p>	<p>NR 80</p>														
	<p>Matryca kwadrat (mm)</p> <p>4,2 ÷ 29,2 Wielkość co 0,5 mm</p>	<p>NR 80</p>														
	<p>Matryca prostokąt (mm)</p> <table border="0"> <tbody> <tr> <td>8x9÷8x48</td> <td>15x16÷15x42</td> </tr> <tr> <td>9x10÷9x50</td> <td>16x17÷16x42</td> </tr> <tr> <td>10x11÷10x42</td> <td>17x18÷17x42</td> </tr> <tr> <td>11x12÷11x42</td> <td>18x19÷18x42</td> </tr> <tr> <td>12x13÷12x42</td> <td>19x20÷20x42</td> </tr> <tr> <td>13x14÷13x42</td> <td>24x25÷24x42</td> </tr> <tr> <td>14x15÷14x42</td> <td>30x31÷30x39</td> </tr> </tbody> </table>	8x9÷8x48	15x16÷15x42	9x10÷9x50	16x17÷16x42	10x11÷10x42	17x18÷17x42	11x12÷11x42	18x19÷18x42	12x13÷12x42	19x20÷20x42	13x14÷13x42	24x25÷24x42	14x15÷14x42	30x31÷30x39	<p>NR 80</p>
8x9÷8x48	15x16÷15x42															
9x10÷9x50	16x17÷16x42															
10x11÷10x42	17x18÷17x42															
11x12÷11x42	18x19÷18x42															
12x13÷12x42	19x20÷20x42															
13x14÷13x42	24x25÷24x42															
14x15÷14x42	30x31÷30x39															
	<p>Matryca niecentryczna \varnothing (mm)</p> <p>3,2 ÷ 20,7 Wielkość co 0,5 mm</p>	<p>NR 80</p>														

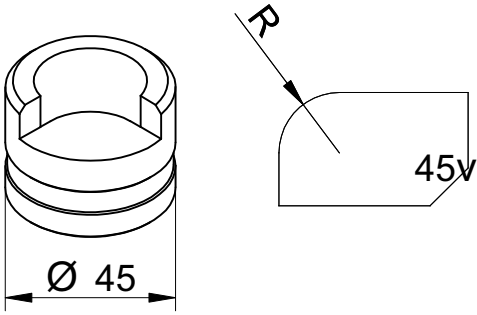
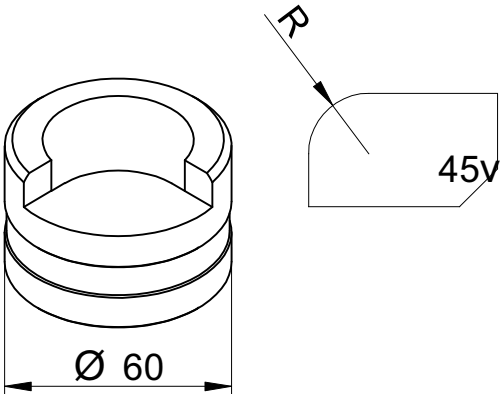
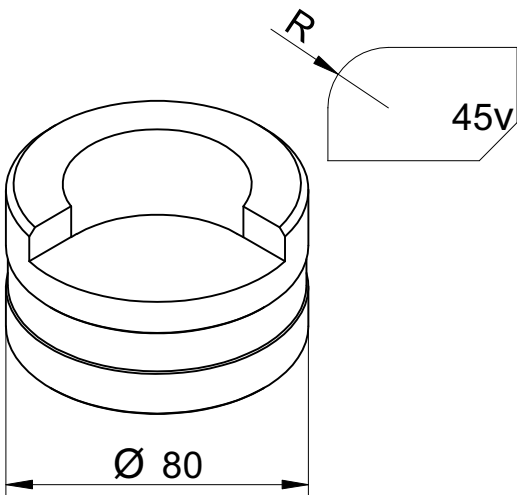
 <p>Ø 45</p>	<p>Zaokrąglanie (mm)</p> <table border="1"> <tbody> <tr><td>R 5</td><td>R 10</td><td>R 15</td></tr> <tr><td>R 6</td><td>R 11</td><td></td></tr> <tr><td>R 7</td><td>R 12</td><td></td></tr> <tr><td>R 8</td><td>R 13</td><td></td></tr> <tr><td>R 9</td><td>R 14</td><td></td></tr> </tbody> </table>	R 5	R 10	R 15	R 6	R 11		R 7	R 12		R 8	R 13		R 9	R 14		<p>NR 45</p>			
R 5	R 10	R 15																		
R 6	R 11																			
R 7	R 12																			
R 8	R 13																			
R 9	R 14																			
 <p>Ø 60</p>	<p>Zaokrąglanie (mm)</p> <table border="1"> <tbody> <tr><td>R 5</td><td>R 11</td><td>R 17</td></tr> <tr><td>R 6</td><td>R 12</td><td>R 18</td></tr> <tr><td>R 7</td><td>R 13</td><td>R 19</td></tr> <tr><td>R 8</td><td>R 14</td><td>R 20</td></tr> <tr><td>R 9</td><td>R 15</td><td></td></tr> <tr><td>R 10</td><td>R 16</td><td></td></tr> </tbody> </table>	R 5	R 11	R 17	R 6	R 12	R 18	R 7	R 13	R 19	R 8	R 14	R 20	R 9	R 15		R 10	R 16		<p>NR 60</p>
R 5	R 11	R 17																		
R 6	R 12	R 18																		
R 7	R 13	R 19																		
R 8	R 14	R 20																		
R 9	R 15																			
R 10	R 16																			
 <p>Ø 80</p>	<p>Zaokrąglanie (mm)</p> <table border="1"> <tbody> <tr><td>R 5</td><td>R 11</td><td>R 17</td></tr> <tr><td>R 6</td><td>R 12</td><td>R 18</td></tr> <tr><td>R 7</td><td>R 13</td><td>R 19</td></tr> <tr><td>R 8</td><td>R 14</td><td>R 20</td></tr> <tr><td>R 9</td><td>R 15</td><td>R 25</td></tr> <tr><td>R 10</td><td>R 16</td><td></td></tr> </tbody> </table>	R 5	R 11	R 17	R 6	R 12	R 18	R 7	R 13	R 19	R 8	R 14	R 20	R 9	R 15	R 25	R 10	R 16		<p>NR 80</p>
R 5	R 11	R 17																		
R 6	R 12	R 18																		
R 7	R 13	R 19																		
R 8	R 14	R 20																		
R 9	R 15	R 25																		
R 10	R 16																			

	<p>Rozcinanie i zaokrąglanie (mm)</p> <p>R 5 R 10</p> <p>R 6</p> <p>R 7</p> <p>R 8</p> <p>R 9</p>	<p>NR 45</p>
	<p>Rozcinanie i zaokrąglanie (mm)</p> <p>R 5 R 11</p> <p>R 6 R 12</p> <p>R 7</p> <p>R 8</p> <p>R 9</p> <p>R 10</p>	<p>NR 60</p>
	<p>Rozcinanie i zaokrąglanie (mm)</p> <p>R 5 R 11</p> <p>R 6 R 12</p> <p>R 7 R 13</p> <p>R 8 R 14</p> <p>R 9 R 15</p> <p>R 10</p>	<p>NR 80</p>

Narzędzia specjalne

Istnieje możliwość wykonania stempli i matryc o specjalnych wymiarach, z indywidualnym luzem.
Wykonanie na podstawie szkicu lub rysunku.

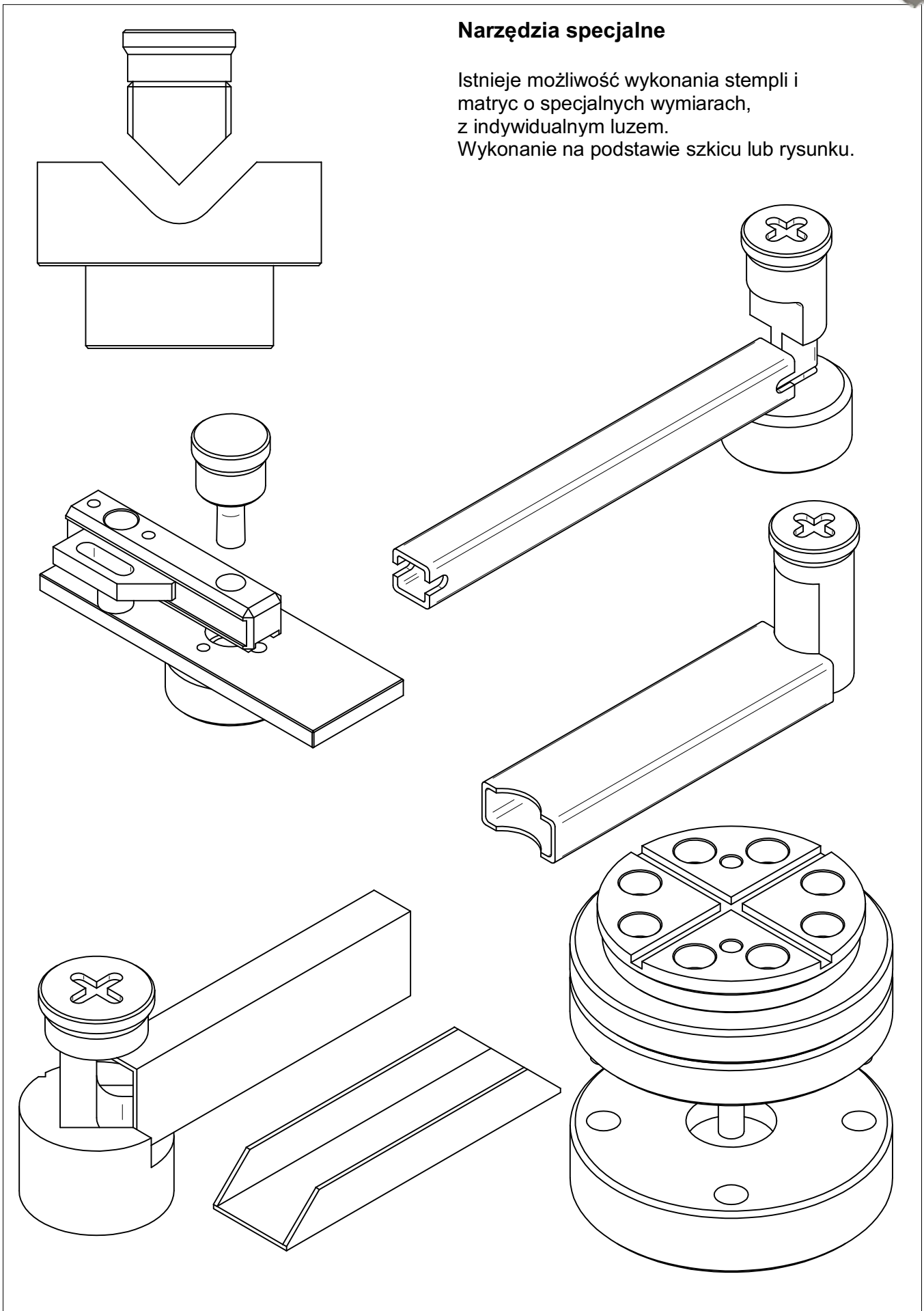

Narzędzia specjalne

Istnieje możliwość wykonania stempli i matryc o specjalnych wymiarach, z indywidualnym luzem.
Wykonanie na podstawie szkicu lub rysunku.

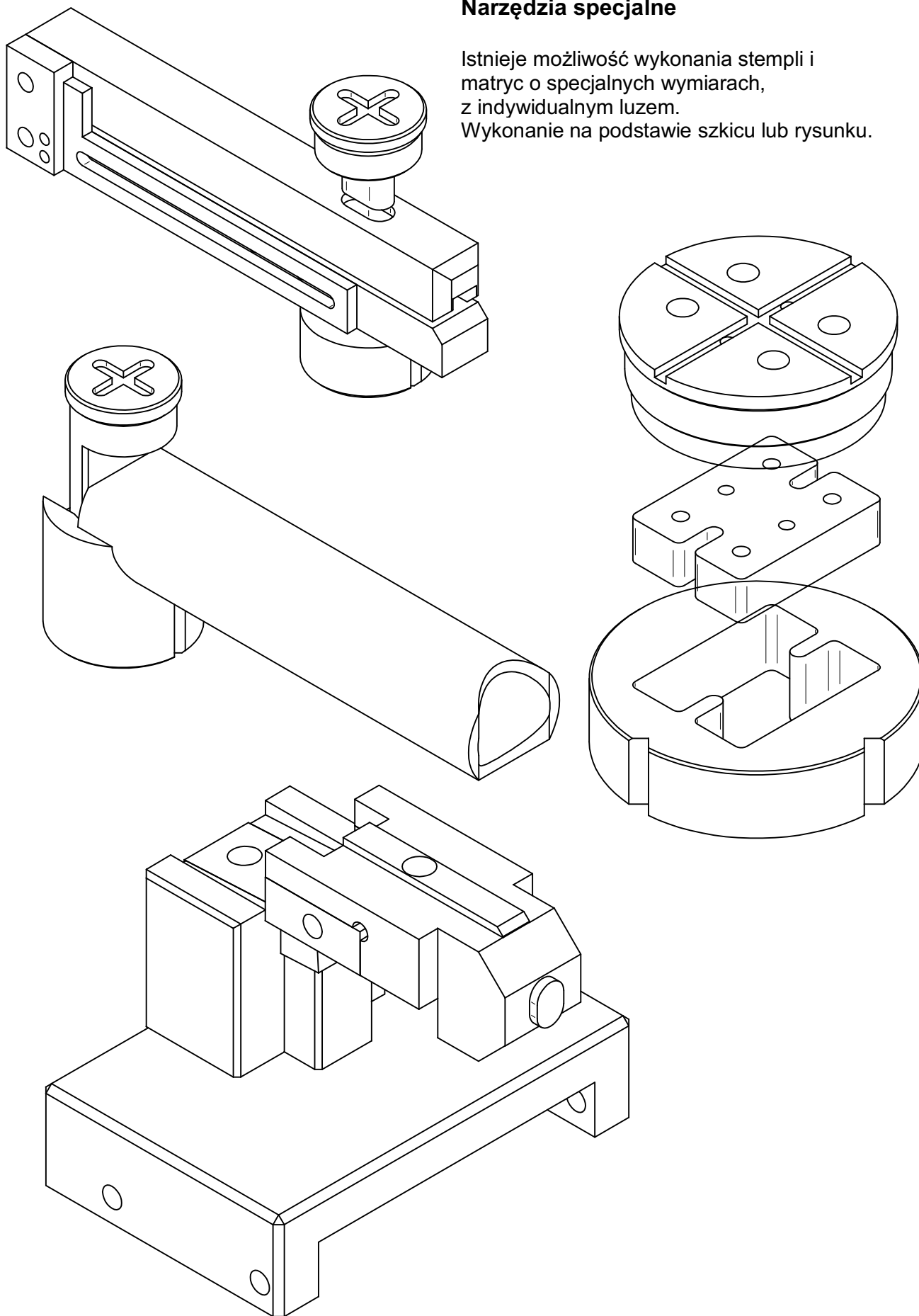

Narzędzia specjalne

Istnieje możliwość wykonania stempli i matryc o specjalnych wymiarach, z indywidualnym luzem.
Wykonanie na podstawie szkicu lub rysunku.

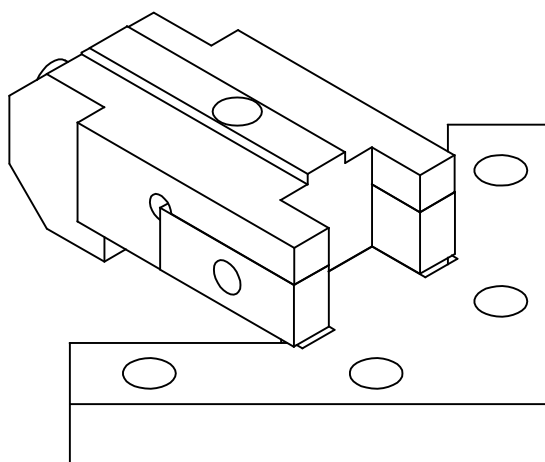
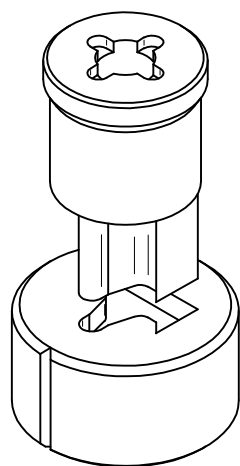
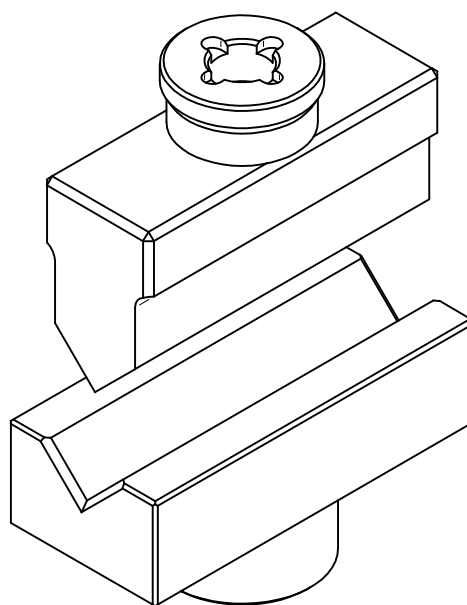
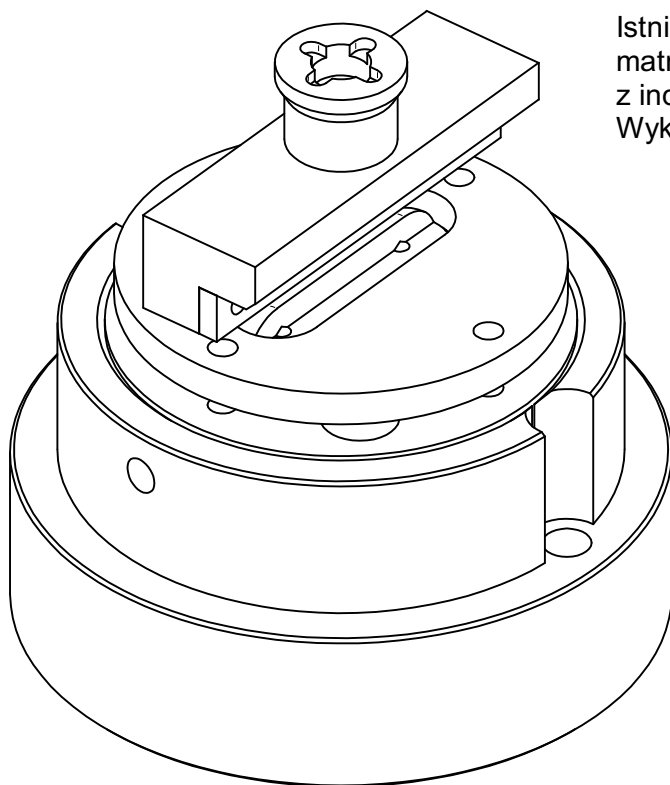



PROJEKTOWANIE I WYKONAWSTWO:

- WYKROJNIKÓW • OKROJNIKÓW • STEPLI I MATRYC DO PRZETŁACZANIA
- STEPLI I MATRYC DO WYCINANIA • OBRÓBKA CNC
- GRAWEROWANIE TECHNICZNE • OBRÓBKA CIEPLNA



WROMET Sp. z o.o.
ul. Kaczeńcowa 2
62-510 Konin

tel. +48 63 245 80 01
info@wromet.com.pl

NIP PL 665-294-89-81
KRS: 000362355