

STEMPLE, MATRYCE DO MASZYNY GEKA



wromet.com.pl

Narzędzia do maszyn GEKA

Modell	Nr. Stempel	Nr. Matrize
MULTIII	1	1 1A
	2	2
MICROCROP MINICROPMULTICROP HYD5070 P.P.50, PUMA5070 IW4545M	515	5
	527	
	6	6
BENDICROP	831	5
HYD5580	819	
PUMA5580 IW5580	831	8
	840	
HYD100	819	
PUMA100	831	
HYD110 PUMA110 IW110	819	10
	831	
	840	
HYD150200	1026	
PUMA150200	1040	
MINICROPMULTICROP HYD5070100 PUMA5070100 HYD5580110 PUMA5580110	11	11
	12	12
	13	13
HYD150200 PUMA150200	11A	11
	12A	12
	13A	13

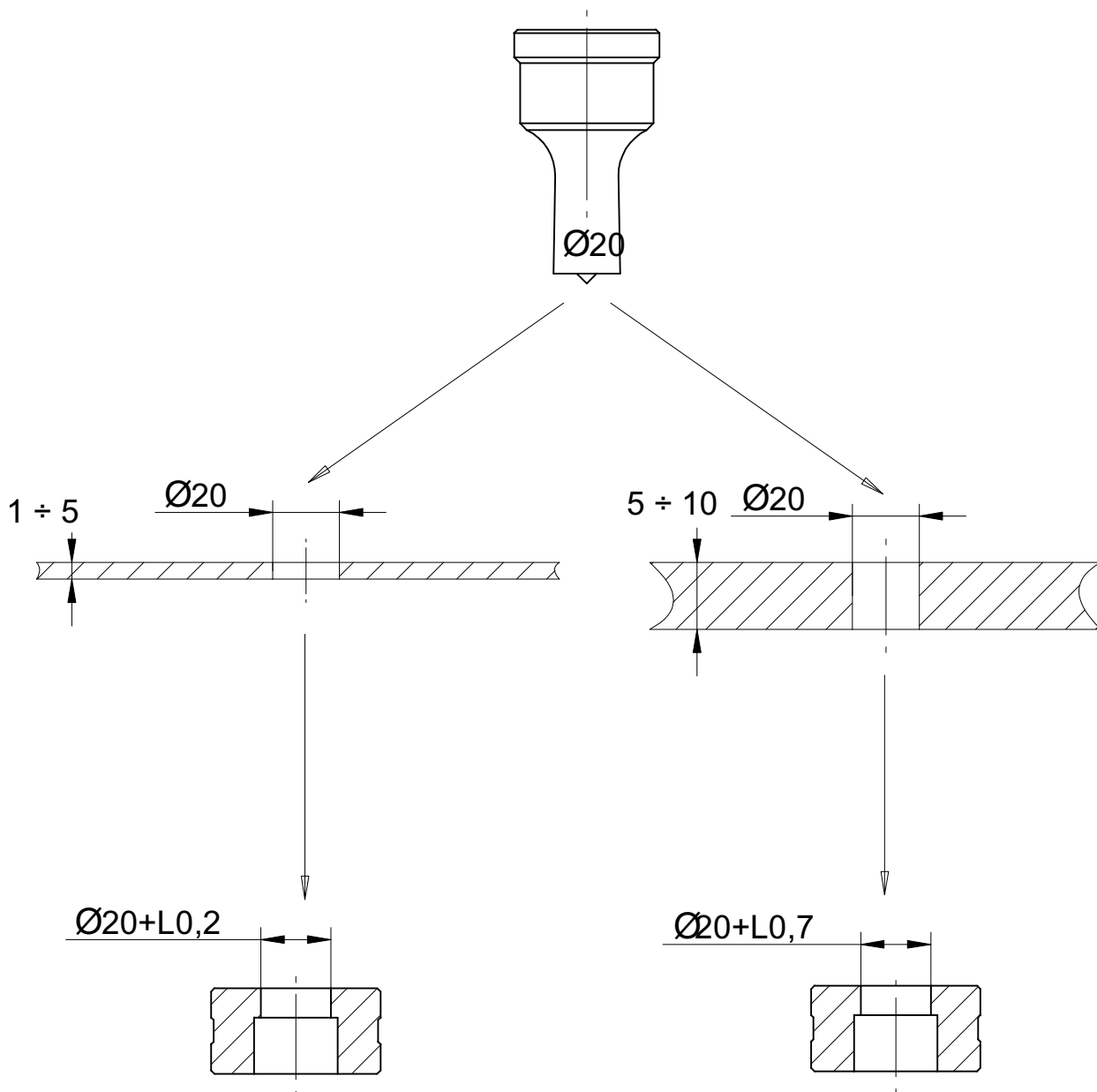

Stempel określa wymiar wykrojonego otworu.
Otwór w matrycy odpowiada rozmiarowi stempla + luz
Dla cienkich blach produkujemy 0,2 mm, dla grubych blach 0,7 mm.
Istnieje możliwość wykonania stempla i matrycy o specjalnych wymiarach i z indywidualnym luzem.

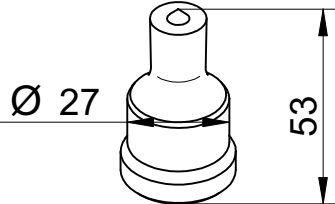
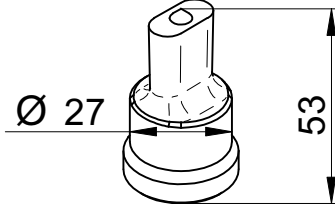
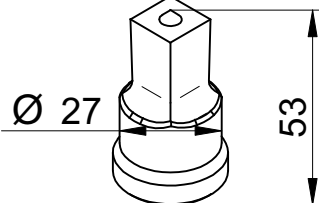
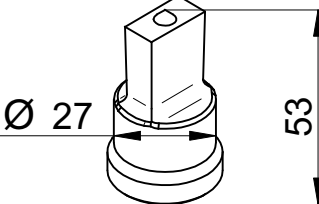
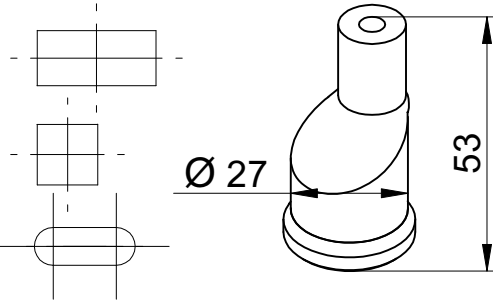
	<p>Stempel okrągły \varnothing (mm)</p> <p>3,0 ÷ 27,0 Wielkość co 0,5 mm</p>	<p>NR 5/27</p>
	<p>Stempel owalny (mm)</p> <p>5,5x10 ÷ 26,0x27,0 Wielkość co 0,5 mm</p>	<p>NR 5/27</p>
	<p>Stempel kwadrat (mm)</p> <p>4,0 ÷ 20,0 Wielkość co 0,5 mm</p>	<p>NR 5/27</p>
	<p>Stempel prostokąt (mm)</p> <p>7,0x10,0 ÷ 15,0x21,0 Wielkość co 0,5 mm</p>	<p>NR 5/27</p>
	<p>Stempel niecentryczny \varnothing (mm)</p> <p>3,0 ÷ 20,0 Wielkość co 0,5 mm</p>	<p>NR 5/27</p>

	<p>Stempel okrągły \varnothing (mm)</p> <p>3,0 ÷ 31,0 Wielkość co 0,5 mm</p>	<p>NR 8/31</p>
	<p>Stempel owalny (mm)</p> <p>5,5x10 ÷ 22,0x31,0 Wielkość co 0,5 mm</p>	<p>NR 8/31</p>
	<p>Stempel kwadrat (mm)</p> <p>4,0 ÷ 22,0 Wielkość co 0,5 mm</p>	<p>NR 8/31</p>
	<p>Stempel prostokąt (mm)</p> <p>8x9÷8x28 15x16÷15x24 9x10÷9x28 10x11÷10x25 11x12÷11x25 12x13÷12x25 13x14÷13x25 14x15÷14x25</p>	<p>NR 8/31</p>
	<p>Stempel niecentryczny \varnothing (mm)</p> <p>3,0 ÷ 15,0 Wielkość co 0,5 mm</p>	<p>NR 8/31</p>

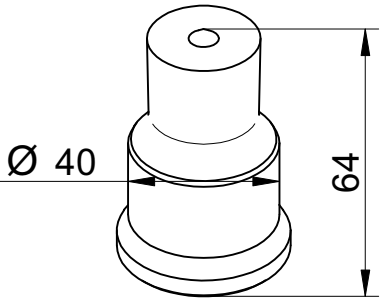
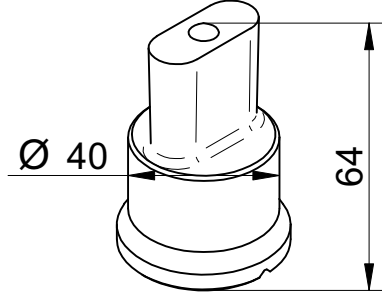
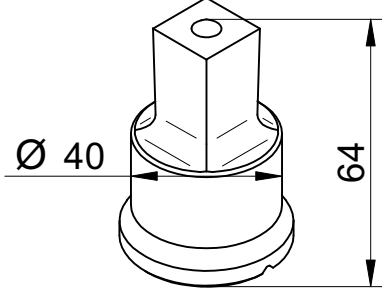
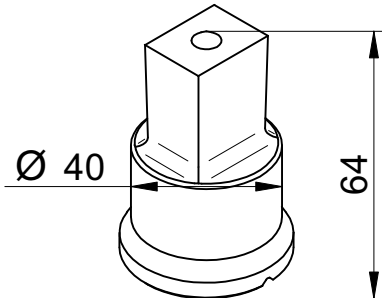
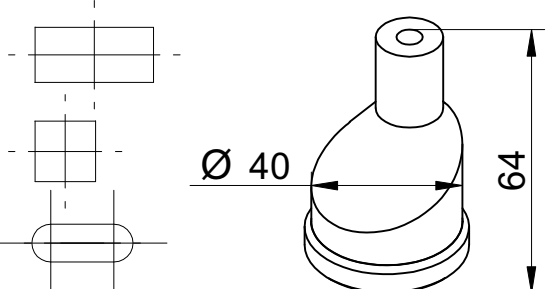
	<p>Stempel okrągły \varnothing (mm)</p> <p>3,0 ÷ 30,0 Wielkość co 0,5 mm</p>	<p>NR 8/40</p> <p>25</p>
	<p>Stempel owalny (mm)</p> <p>5,5x10 ÷ 38,0x40,0 Wielkość co 0,5 mm</p>	<p>NR 8/40</p>
	<p>Stempel kwadrat (mm)</p> <p>4,0 ÷ 28,0 Wielkość co 0,5 mm</p>	<p>NR 8/40</p>
	<p>Stempel prostokąt (mm)</p> <p>8x9÷8x35 15x16÷15x30 9x10÷9x35 16x17÷16x30 10x11÷10x30 17x18÷17x30 11x12÷11x30 18x19÷18x30 12x13÷12x30 19x20÷20x30 13x14÷13x30 24x25÷24x30 14x15÷14x30</p>	<p>NR 8/40</p>
	<p>Stempel niecentryczny \varnothing (mm)</p> <p>3,0 ÷ 20,0 Wielkość co 0,5 mm</p>	<p>NR 8/40</p>

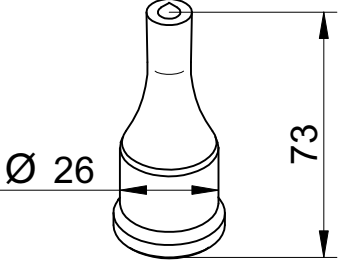
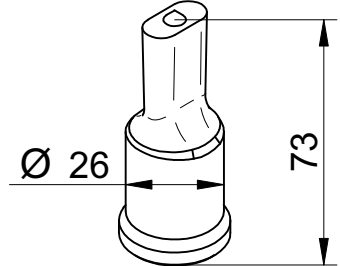
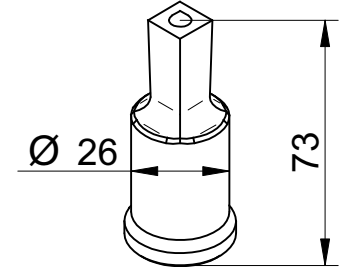
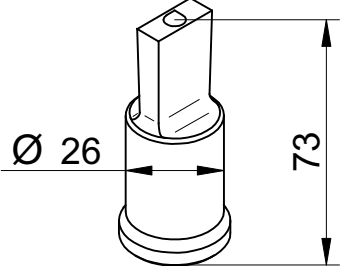
	<p>Stempel okrągły \varnothing (mm)</p> <p>3,0 ÷ 26,0 Wielkość co 0,5 mm</p>	<p>NR 10/26</p>
	<p>Stempel owalny (mm)</p> <p>5,5x10 ÷ 22,0x26,0 Wielkość co 0,5 mm</p>	<p>NR 10/26</p>
	<p>Stempel kwadrat (mm)</p> <p>4,0 ÷ 21,0 Wielkość co 0,5 mm</p>	<p>NR 10/26</p>
	<p>Stempel prostokąt (mm)</p> <p>8x9÷8x20 15x16÷15x20 9x10÷9x20 10x11÷10x20 11x12÷11x20 12x13÷12x20 13x14÷13x20 14x15÷14x20</p>	<p>NR 10/26</p>

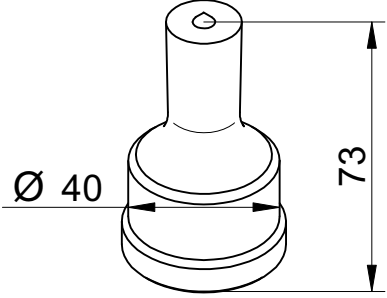
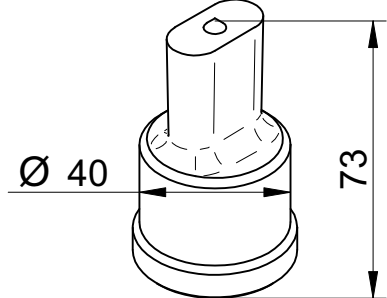
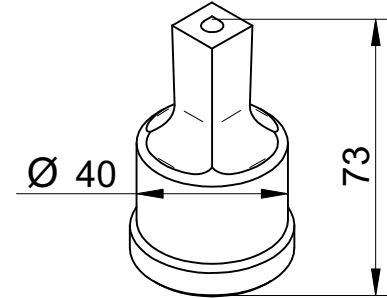
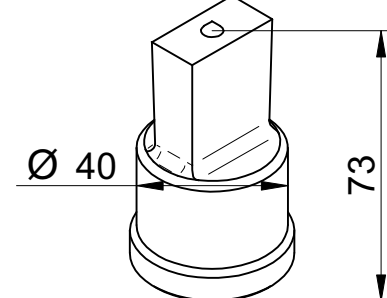
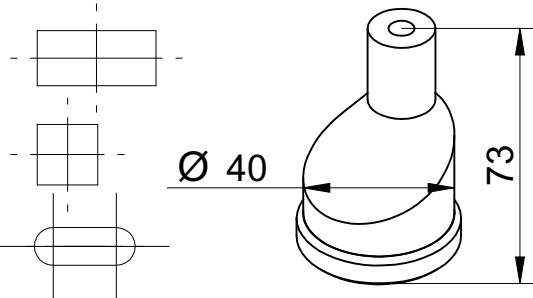
	<p>Stempel okrągły \varnothing (mm)</p> <p>3,0 ÷ 40,0 Wielkość co 0,5 mm</p>	<p>NR 10/40</p>
	<p>Stempel owalny (mm)</p> <p>5,5x10 ÷ 38,0x40,0 Wielkość co 0,5 mm</p>	<p>NR 10/40</p>
	<p>Stempel kwadrat (mm)</p> <p>4,0 ÷ 28,0 Wielkość co 0,5 mm</p>	<p>NR 10/40</p>
	<p>Stempel prostokąt (mm)</p> <p>8,0x35,0 ÷ 20,0x30,0 Wielkość co 0,5 mm</p>	<p>NR 10/40</p>
	<p>Stempel niecentryczny \varnothing (mm)</p> <p>3,0 ÷ 20,0 Wielkość co 0,5 mm</p>	<p>NR 10/40</p>

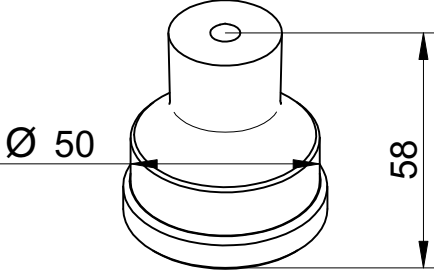
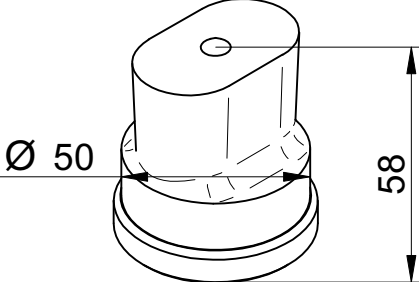
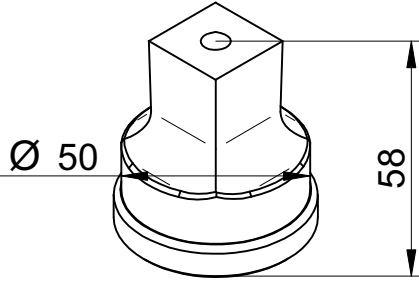
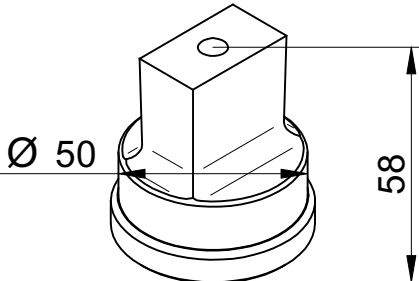
	<p>Stempel okrągły \varnothing (mm)</p> <p>10,0 ÷ 50,0 Wielkość co 0,5 mm</p>	<p>NR 11</p>
	<p>Stempel owalny (mm)</p> <p>10,0x50,0 ÷ 40,0x50,0 Wielkość co 0,5 mm</p>	<p>NR 11</p>
	<p>Stempel kwadrat (mm)</p> <p>10,0 ÷ 35,0 Wielkość co 0,5 mm</p>	<p>NR 11</p>
	<p>Stempel prostokąt (mm)</p> <p>10,0x45,0 ÷ 30,0x38,0 Wielkość co 0,5 mm</p>	<p>NR 11</p>

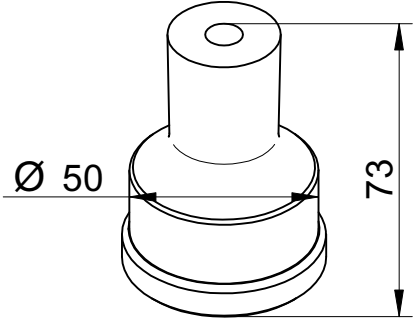
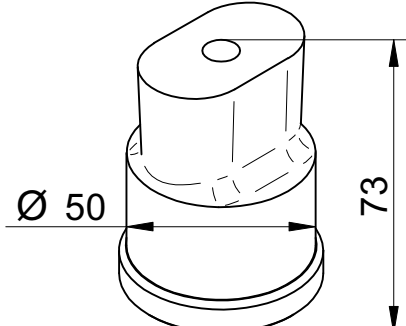
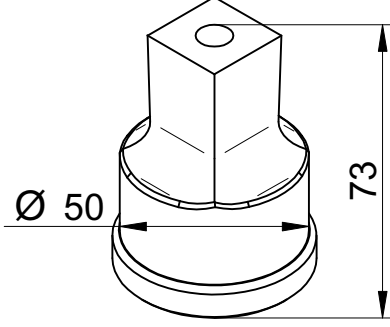
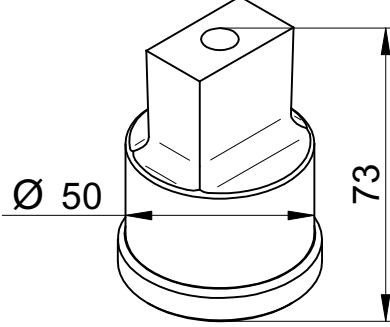
	<p>Stempel okrągły \varnothing (mm)</p> <p>10,0 ÷ 50,0 Wielkość co 0,5 mm</p>	<p>NR 11A</p>
	<p>Stempel owalny (mm)</p> <p>10,0x50,0 ÷ 40,0x50,0 Wielkość co 0,5 mm</p>	<p>NR 11A</p>
	<p>Stempel kwadrat (mm)</p> <p>10,0 ÷ 35,0 Wielkość co 0,5 mm</p>	<p>NR 11A</p>
	<p>Stempel prostokąt (mm)</p> <p>10,0x45,0 ÷ 30,0x38,0 Wielkość co 0,5 mm</p>	<p>NR 11A</p>

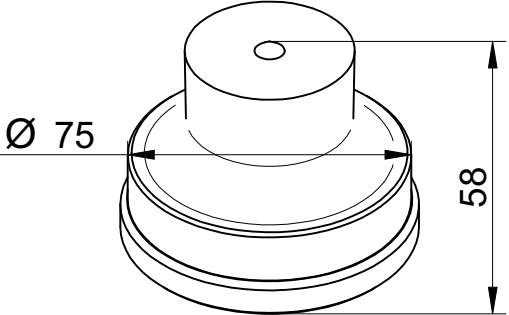
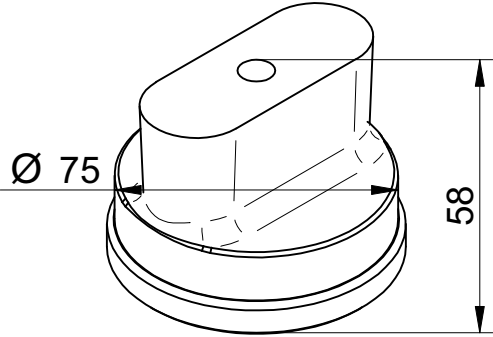
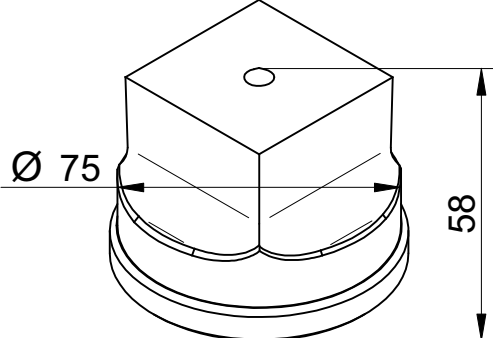
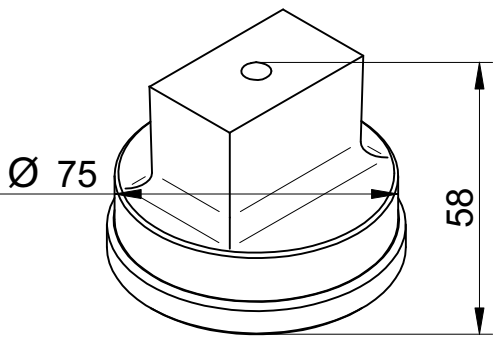
	<p>Stempel okrągły \varnothing (mm)</p> <p>10,0 ÷ 70,0 Wielkość co 0,5 mm</p>	<p>NR 12</p>
	<p>Stempel owalny (mm)</p> <p>10,0x70,0 ÷ 60,0x70,0 Wielkość co 0,5 mm</p>	<p>NR 12</p>
	<p>Stempel kwadrat (mm)</p> <p>10,0 ÷ 50,0 Wielkość co 0,5 mm</p>	<p>NR 12</p>
	<p>Stempel prostokąt (mm)</p> <p>10,0x70,0 ÷ 45,0x60,0 Wielkość co 0,5 mm</p>	<p>NR 12</p>

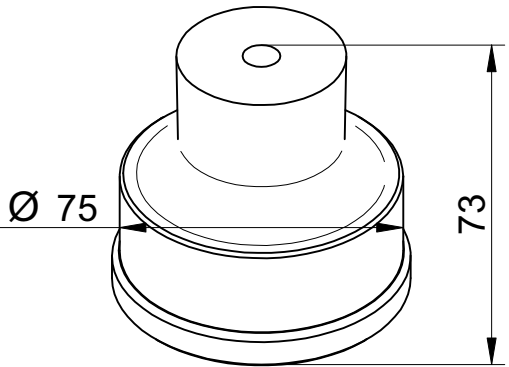
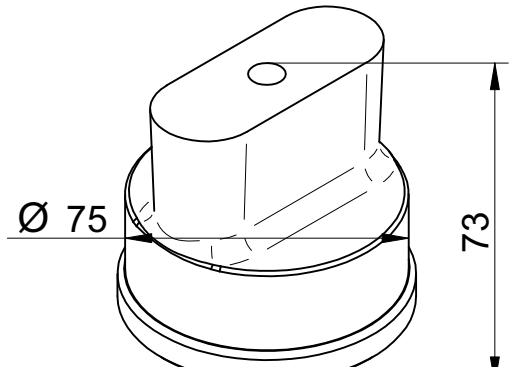
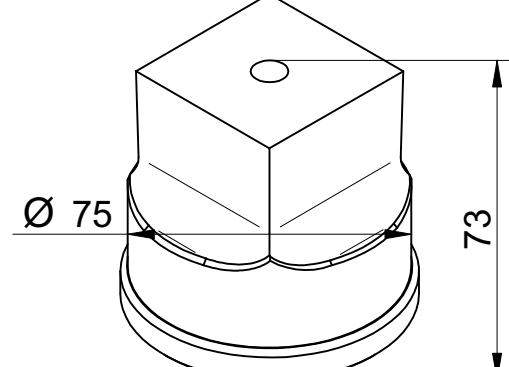
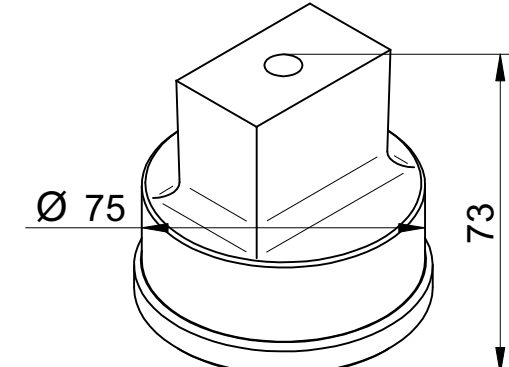
	<p>Stempel okrągły \varnothing (mm)</p> <p>10,0 ÷ 70,0 Wielkość co 0,5 mm</p>	<p>NR 12A</p>
	<p>Stempel owalny (mm)</p> <p>10,0x70,0 ÷ 60,0x70,0 Wielkość co 0,5 mm</p>	<p>NR 12A</p>
	<p>Stempel kwadrat (mm)</p> <p>10,0 ÷ 50,0 Wielkość co 0,5 mm</p>	<p>NR 12A</p>
	<p>Stempel prostokąt (mm)</p> <p>10,0x70,0 ÷ 45,0x60,0 Wielkość co 0,5 mm</p>	<p>NR 12A</p>

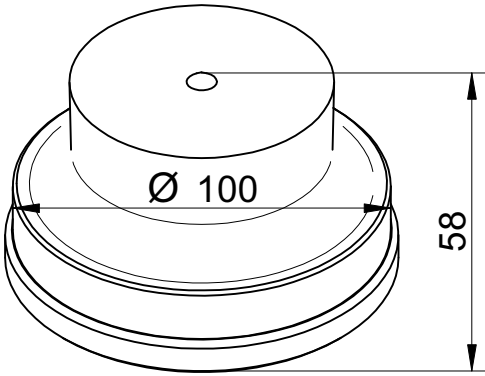
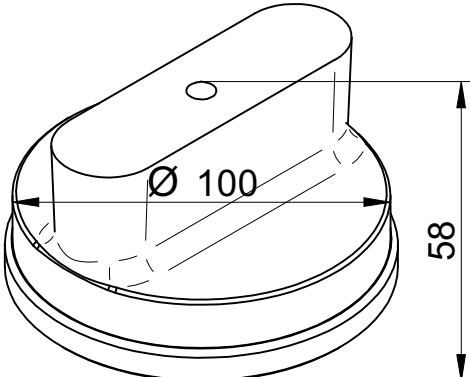
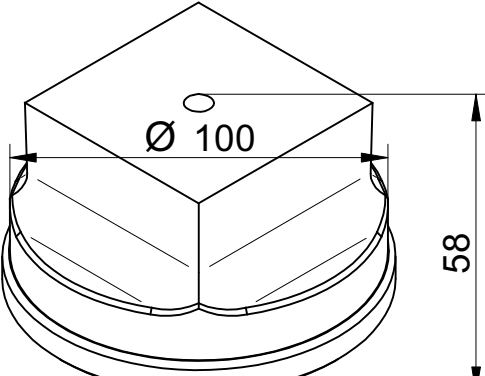
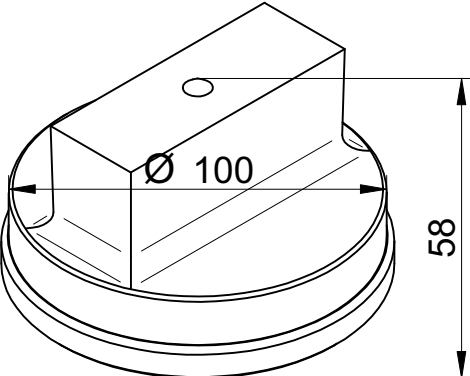
	<p>Stempel okrągły \varnothing (mm)</p> <p>10,0 ÷ 100,0 Wielkość co 0,5 mm</p>	<p>NR 13</p>
	<p>Stempel owalny (mm)</p> <p>10,0x100,0 ÷ 80,0x100,0 Wielkość co 0,5 mm</p>	<p>NR 13</p>
	<p>Stempel kwadrat (mm)</p> <p>10,0 ÷ 70,0 Wielkość co 0,5 mm</p>	<p>NR 13</p>
	<p>Stempel prostokąt (mm)</p> <p>10,0x95,0 ÷ 50,0x80,0 Wielkość co 0,5 mm</p>	<p>NR 13</p>

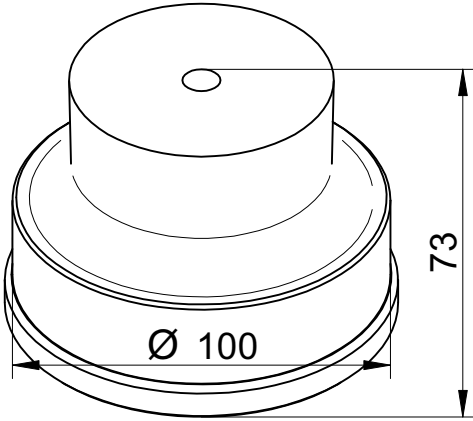
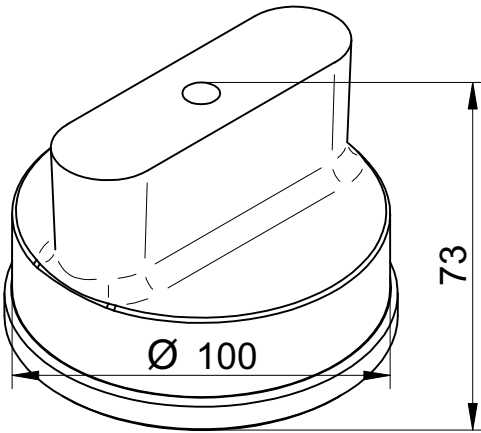
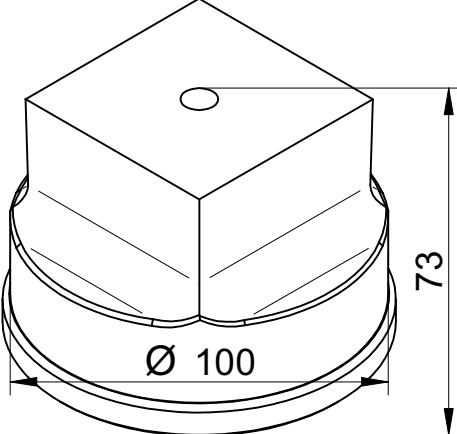
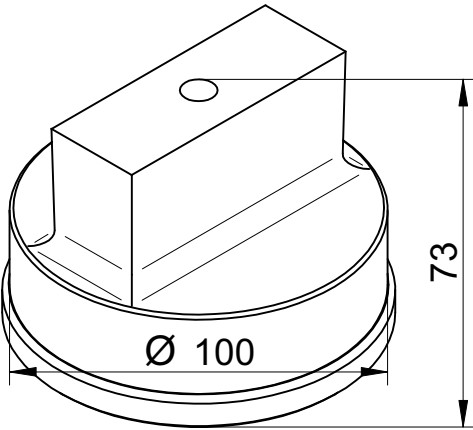
	<p>Matryca okrągły \varnothing (mm)</p> <p>10,0 ÷ 100,0 Wielkość co 0,5 mm</p>	<p>NR 13A</p>
	<p>Matryca owalna (mm)</p> <p>10,0x100,0 ÷ 80,0x100,0 Wielkość co 0,5 mm</p>	<p>NR 13A</p>
	<p>Matryca kwadrat (mm)</p> <p>10,0 ÷ 70,0 Wielkość co 0,5 mm</p>	<p>NR 13A</p>
	<p>Matryca prostokąt (mm)</p> <p>10,0x95,0 ÷ 50,0x80,0 Wielkość co 0,5 mm</p>	<p>NR 13A</p>

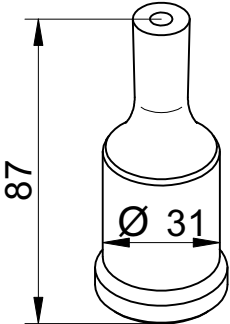
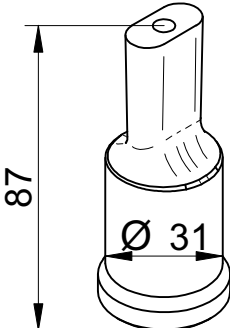
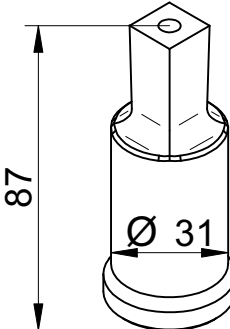
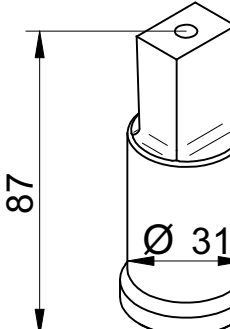
	<p>Stempel okrągły \varnothing (mm)</p> <p>3,0 ÷ 31,0 Wielkość co 0,5 mm</p>	<p>ALPS</p>
	<p>Stempel owalny (mm)</p> <p>5,5x10 ÷ 22,0x31,0 Wielkość co 0,5 mm</p>	<p>ALPS</p>
	<p>Stempel kwadrat (mm)</p> <p>4,0 ÷ 22,0 Wielkość co 0,5 mm</p>	<p>ALPS</p>
	<p>Stempel prostokąt (mm)</p> <p>8x9÷8x28 15x16÷15x24 9x10÷9x28 10x11÷10x25 11x12÷11x25 12x13÷12x25 13x14÷13x25 14x15÷14x25</p>	<p>ALPS</p>

	<p>Zaokrąglanie (mm)</p> <table border="1"> <tr><td>R 5</td><td>R 10</td><td>R 15</td></tr> <tr><td>R 6</td><td>R 11</td><td></td></tr> <tr><td>R 7</td><td>R 12</td><td></td></tr> <tr><td>R 8</td><td>R 13</td><td></td></tr> <tr><td>R 9</td><td>R 14</td><td></td></tr> </table>	R 5	R 10	R 15	R 6	R 11		R 7	R 12		R 8	R 13		R 9	R 14		<p>NR 5</p>
R 5	R 10	R 15															
R 6	R 11																
R 7	R 12																
R 8	R 13																
R 9	R 14																
	<p>Zaokrąglanie (mm)</p> <table border="1"> <tr><td>R 5</td><td>R 10</td><td>R 15</td></tr> <tr><td>R 6</td><td>R 11</td><td></td></tr> <tr><td>R 7</td><td>R 12</td><td></td></tr> <tr><td>R 8</td><td>R 13</td><td></td></tr> <tr><td>R 9</td><td>R 14</td><td></td></tr> </table>	R 5	R 10	R 15	R 6	R 11		R 7	R 12		R 8	R 13		R 9	R 14		<p>NR 8/31</p>
R 5	R 10	R 15															
R 6	R 11																
R 7	R 12																
R 8	R 13																
R 9	R 14																
	<p>Zaokrąglanie (mm)</p> <table border="1"> <tr><td>R 5</td><td>R 10</td><td>R 15</td></tr> <tr><td>R 6</td><td>R 11</td><td></td></tr> <tr><td>R 7</td><td>R 12</td><td></td></tr> <tr><td>R 8</td><td>R 13</td><td></td></tr> <tr><td>R 9</td><td>R 14</td><td></td></tr> </table>	R 5	R 10	R 15	R 6	R 11		R 7	R 12		R 8	R 13		R 9	R 14		<p>NR 8/40</p>
R 5	R 10	R 15															
R 6	R 11																
R 7	R 12																
R 8	R 13																
R 9	R 14																
	<p>Zaokrąglanie (mm)</p> <table border="1"> <tr><td>R 5</td><td>R 10</td><td>R 15</td></tr> <tr><td>R 6</td><td>R 11</td><td>R 16</td></tr> <tr><td>R 7</td><td>R 12</td><td>R 17</td></tr> <tr><td>R 8</td><td>R 13</td><td>R 18</td></tr> <tr><td>R 9</td><td>R 14</td><td>R 20</td></tr> </table>	R 5	R 10	R 15	R 6	R 11	R 16	R 7	R 12	R 17	R 8	R 13	R 18	R 9	R 14	R 20	<p>NR 11</p>
R 5	R 10	R 15															
R 6	R 11	R 16															
R 7	R 12	R 17															
R 8	R 13	R 18															
R 9	R 14	R 20															
	<p>Zaokrąglanie (mm)</p> <p>R10 ÷ R45 Wielkość co 1 mm</p>	<p>NR 12 NR 13</p>															

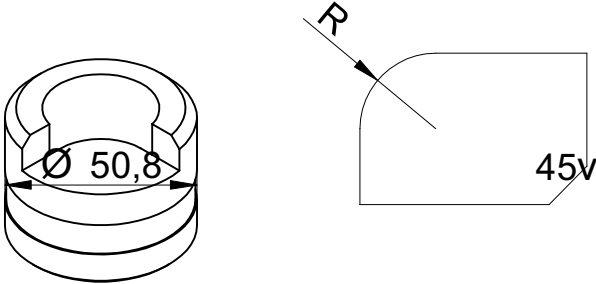
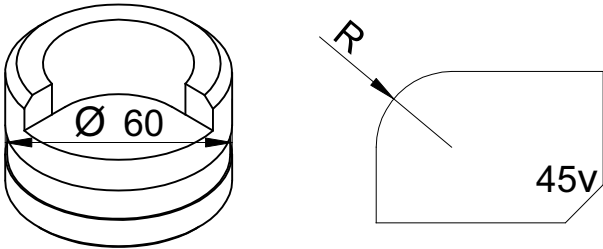
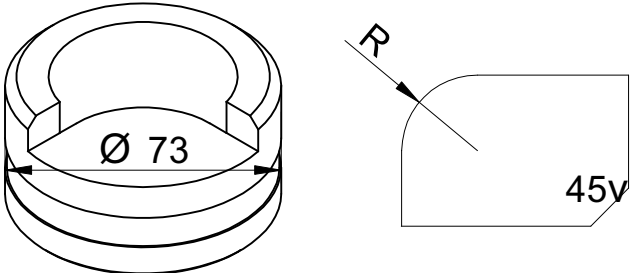
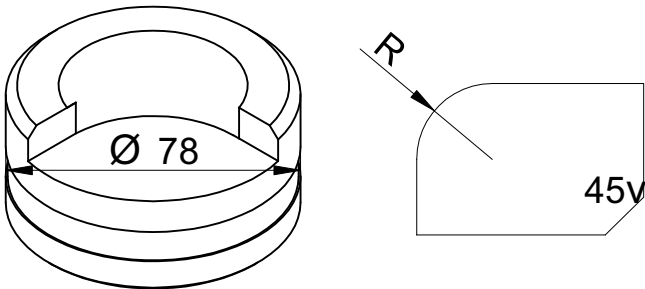
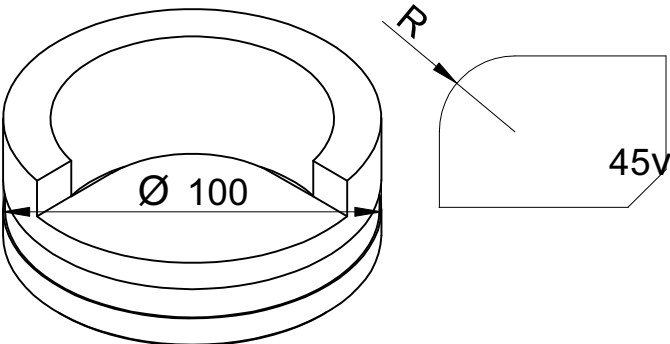
	<p>Zaokrąglanie (mm)</p> <table border="1"> <tr><td>R 5</td><td>R 10</td><td>R 15</td></tr> <tr><td>R 6</td><td>R 11</td><td></td></tr> <tr><td>R 7</td><td>R 12</td><td></td></tr> <tr><td>R 8</td><td>R 13</td><td></td></tr> <tr><td>R 9</td><td>R 14</td><td></td></tr> </table>	R 5	R 10	R 15	R 6	R 11		R 7	R 12		R 8	R 13		R 9	R 14		<p>NR 5</p>
R 5	R 10	R 15															
R 6	R 11																
R 7	R 12																
R 8	R 13																
R 9	R 14																
	<p>Zaokrąglanie (mm)</p> <table border="1"> <tr><td>R 5</td><td>R 10</td><td>R 15</td></tr> <tr><td>R 6</td><td>R 11</td><td></td></tr> <tr><td>R 7</td><td>R 12</td><td></td></tr> <tr><td>R 8</td><td>R 13</td><td></td></tr> <tr><td>R 9</td><td>R 14</td><td></td></tr> </table>	R 5	R 10	R 15	R 6	R 11		R 7	R 12		R 8	R 13		R 9	R 14		<p>NR 8</p>
R 5	R 10	R 15															
R 6	R 11																
R 7	R 12																
R 8	R 13																
R 9	R 14																
	<p>Zaokrąglanie (mm)</p> <table border="1"> <tr><td>R 5</td><td>R 10</td><td>R 15</td></tr> <tr><td>R 6</td><td>R 11</td><td></td></tr> <tr><td>R 7</td><td>R 12</td><td></td></tr> <tr><td>R 8</td><td>R 13</td><td></td></tr> <tr><td>R 9</td><td>R 14</td><td></td></tr> </table>	R 5	R 10	R 15	R 6	R 11		R 7	R 12		R 8	R 13		R 9	R 14		<p>NR 10</p>
R 5	R 10	R 15															
R 6	R 11																
R 7	R 12																
R 8	R 13																
R 9	R 14																
	<p>Zaokrąglanie (mm)</p> <table border="1"> <tr><td>R 5</td><td>R 10</td><td>R 15</td></tr> <tr><td>R 6</td><td>R 11</td><td></td></tr> <tr><td>R 7</td><td>R 12</td><td></td></tr> <tr><td>R 8</td><td>R 13</td><td></td></tr> <tr><td>R 9</td><td>R 14</td><td></td></tr> </table>	R 5	R 10	R 15	R 6	R 11		R 7	R 12		R 8	R 13		R 9	R 14		<p>NR 11</p>
R 5	R 10	R 15															
R 6	R 11																
R 7	R 12																
R 8	R 13																
R 9	R 14																
	<p>Zaokrąglanie (mm)</p> <table border="1"> <tr><td colspan="3">R10 ÷ R45</td></tr> <tr><td colspan="3">Wielkość co 1 mm</td></tr> </table>	R10 ÷ R45			Wielkość co 1 mm			<p>NR 12 NR 13</p>									
R10 ÷ R45																	
Wielkość co 1 mm																	

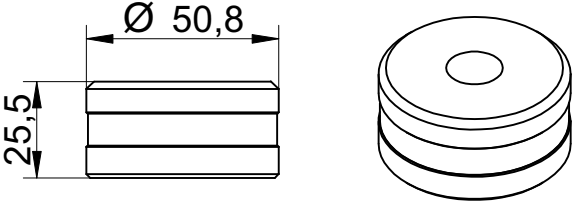
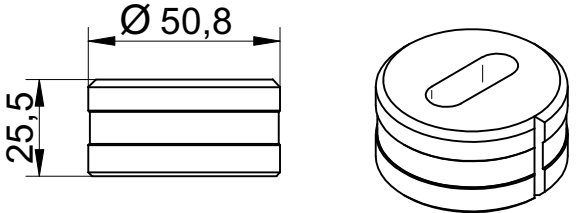
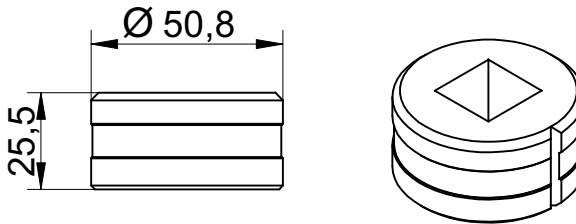
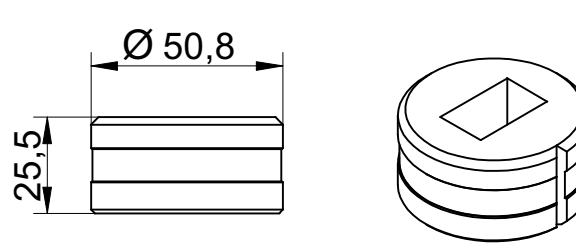
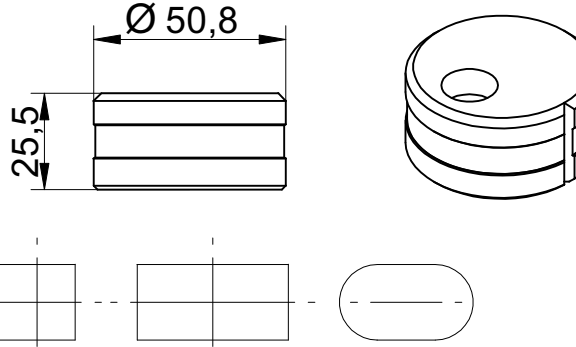
	<p>Matryca okrągła \varnothing (mm)</p> <p>3,2 ÷ 33,2 Wielkość co 0,5 mm</p>	<p>NR 5</p>
	<p>Matryca owalna (mm)</p> <p>5,2x10,2 ÷ 22,7x31,7 Wielkość co 0,5 mm</p>	<p>NR 5</p>
	<p>Matryca kwadrat (mm)</p> <p>4,2 ÷ 22,7 Wielkość co 0,5 mm</p>	<p>NR 5</p>
	<p>Matryca prostokąt (mm)</p> <p>8,2x9,2 ÷ 20,2x30,2 8,7x9,7 ÷ 20,7x30,7 Wielkość co 0,5 mm</p>	<p>NR 5</p>
	<p>Matryca niecentryczna \varnothing (mm)</p> <p>5,7 ÷ 24,7 Wielkość co 0,5 mm</p>	<p>NR 5</p>

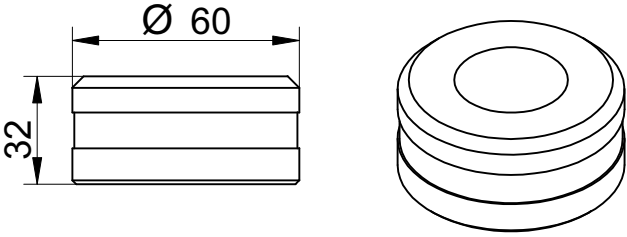
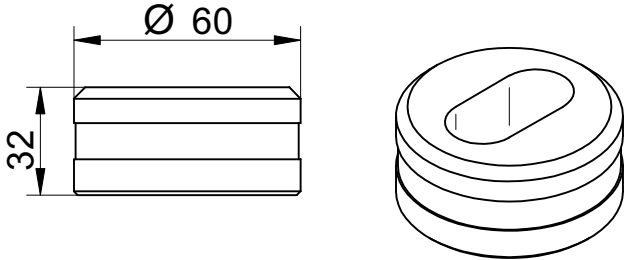
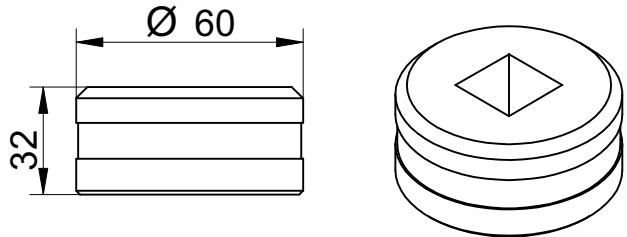
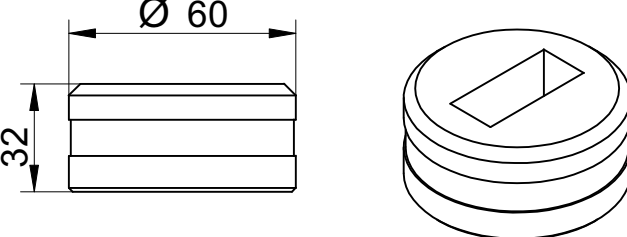
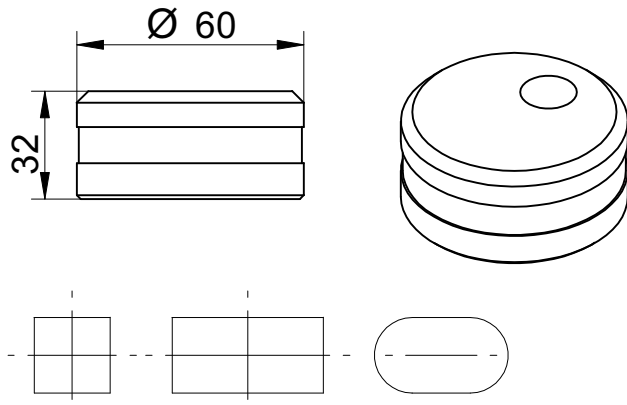
	<p>Matryca okrągła \varnothing (mm)</p> <p>3,2 ÷ 33,2 Wielkość co 0,5 mm</p>	<p>NR 8</p>
	<p>Matryca owalna (mm)</p> <p>5,2x10,2 ÷ 22,7x31,7 Wielkość co 0,5 mm</p>	<p>NR 8</p>
	<p>Matryca kwadrat (mm)</p> <p>4,2 ÷ 22,7 Wielkość co 0,5 mm</p>	<p>NR 8</p>
	<p>Matryca prostokąt (mm)</p> <p>8,2x9,2 ÷ 20,2x30,2 8,7x9,7 ÷ 20,7x30,7 Wielkość co 0,5 mm</p>	<p>NR 8</p>
	<p>Matryca niecentryczna \varnothing (mm)</p> <p>5,7 ÷ 24,7 Wielkość co 0,5 mm</p>	<p>NR 8</p>

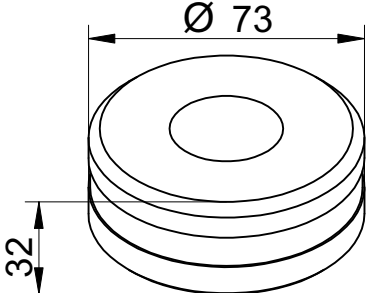
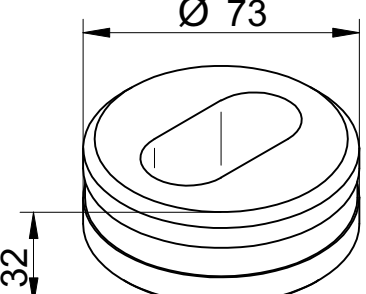
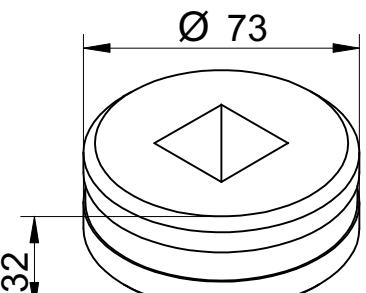
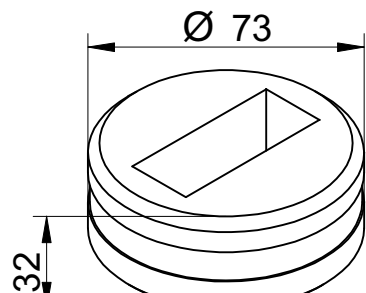
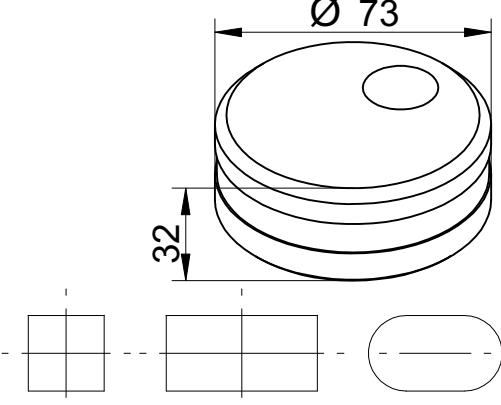
	<p>Matryca okrągła \varnothing (mm)</p> <p>3,2 ÷ 45,2 Wielkość co 0,5 mm</p>	<p>NR 10</p>
	<p>Matryca owalna (mm)</p> <p>5,2x10,2 ÷ 22,7x45,7 Wielkość co 0,5 mm</p>	<p>NR 10</p>
	<p>Matryca kwadrat (mm)</p> <p>4,2 ÷ 40,7 Wielkość co 0,5 mm</p>	<p>NR 10</p>
	<p>Matryca prostokąt (mm)</p> <p>10,2x60,2 ÷ 40,2x50,2 10,7x60,7 ÷ 40,7x50,7 Wielkość co 0,5 mm</p>	<p>NR 10</p>
	<p>Matryca niecentryczna \varnothing (mm)</p> <p>5,7 ÷ 30,7 Wielkość co 0,5 mm</p>	<p>NR 10</p>

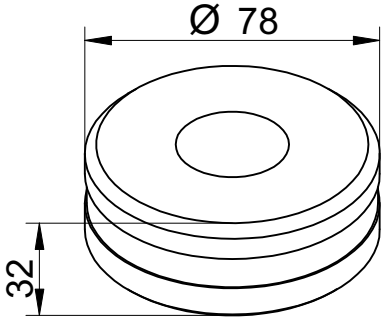
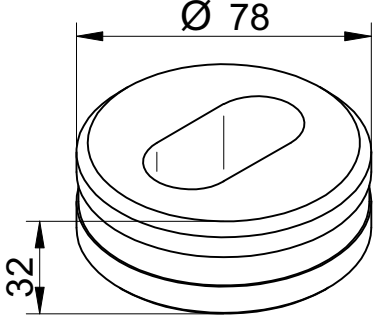
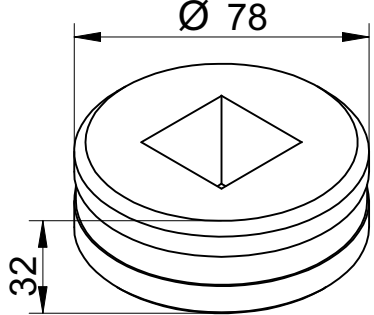
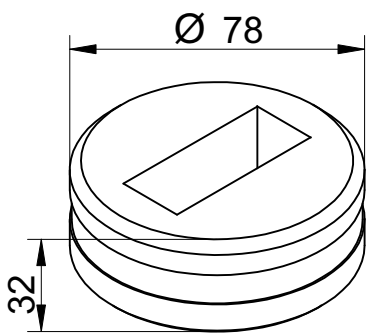
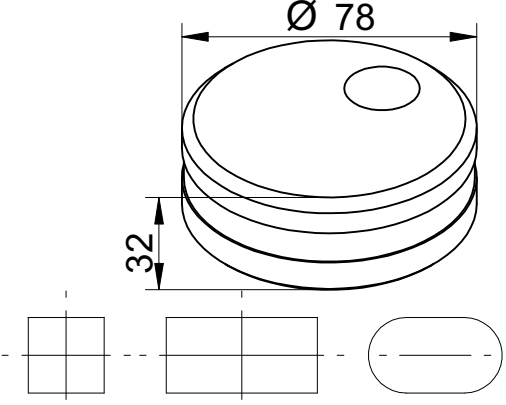
	<p>Matryca okrągła \varnothing (mm)</p> <p>3,2 ÷ 50,2 Wielkość co 0,5 mm</p>	<p>NR 11</p>
	<p>Matryca owalna (mm)</p> <p>5,2x10,2 ÷ 30,7x50,7 Wielkość co 0,5 mm</p>	<p>NR 11</p>
	<p>Matryca kwadrat (mm)</p> <p>4,2 ÷ 45,7 Wielkość co 0,5 mm</p>	<p>NR 11</p>
	<p>Matryca prostokąt (mm)</p> <p>10,2x60,2 ÷ 30,2x55,2 10,7x60,7 ÷ 30,7x55,7 Wielkość co 0,5 mm</p>	<p>NR 11</p>
	<p>Matryca niecentryczna \varnothing (mm)</p> <p>5,7 ÷ 30,7 Wielkość co 0,5 mm</p>	<p>NR 11</p>

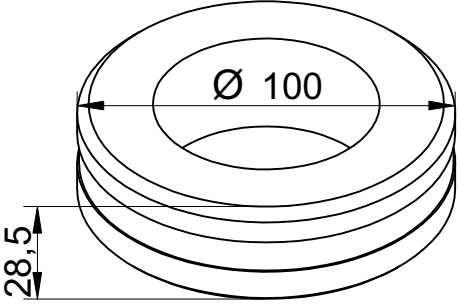
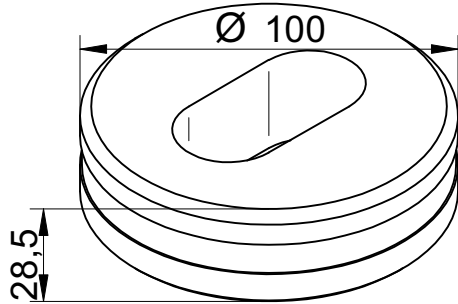
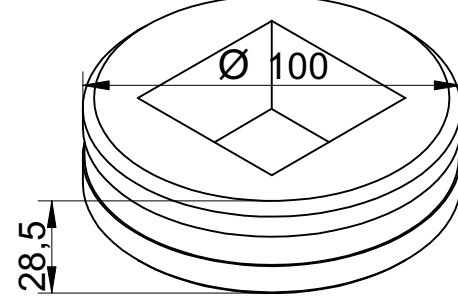
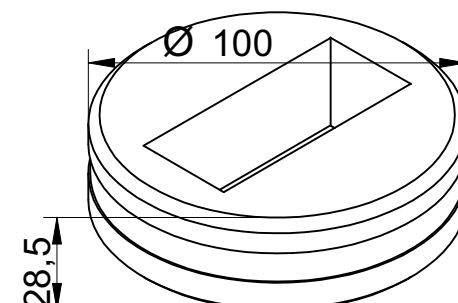
	<p>Matryca okrągła \varnothing (mm)</p> <p>3,2 ÷ 70,2 Wielkość co 0,5 mm</p>	<p>NR 12</p>
	<p>Matryca owalna (mm)</p> <p>5,2x10,2 ÷ 50,7x70,7 Wielkość co 0,5 mm</p>	<p>NR 12</p>
	<p>Matryca kwadrat (mm)</p> <p>4,2 ÷ 55,7 Wielkość co 0,5 mm</p>	<p>NR 12</p>
	<p>Matryca prostokąt (mm)</p> <p>10,2x60,2 ÷ 30,2x70,2 10,7x60,7 ÷ 30,7x70,7 Wielkość co 0,5 mm</p>	<p>NR 12</p>

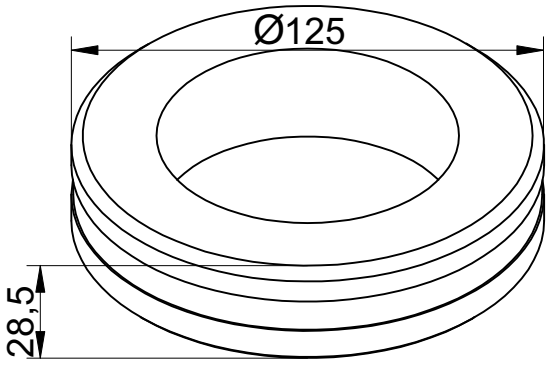
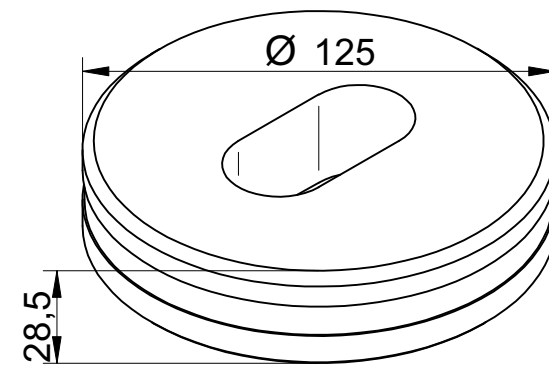
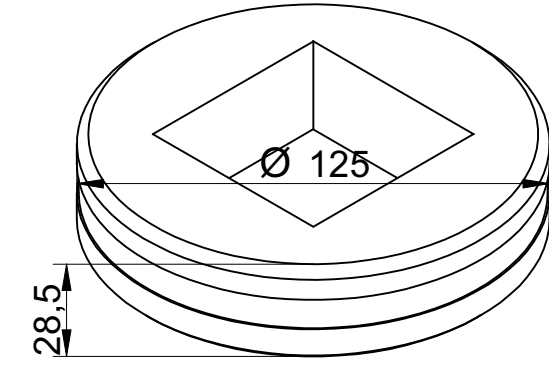
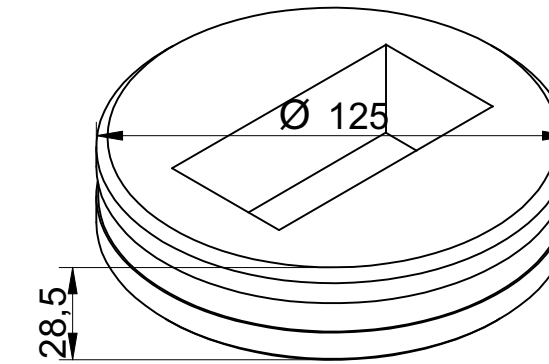
	<p>Matryca okrągła \varnothing (mm)</p> <p>3,2 ÷ 90,2 Wielkość co 0,5 mm</p>	<p>NR 13</p>
	<p>Matryca owalna (mm)</p> <p>5,2x10,2 ÷ 70,7x90,7 Wielkość co 0,5 mm</p>	<p>NR 13</p>
	<p>Matryca kwadrat (mm)</p> <p>4,2 ÷ 60,7 Wielkość co 0,5 mm</p>	<p>NR 13</p>
	<p>Matryca prostokąt (mm)</p> <p>10,2x60,2 ÷ 30,2x80,2 10,7x60,7 ÷ 30,7x80,7 Wielkość co 0,5 mm</p>	<p>NR 13</p>

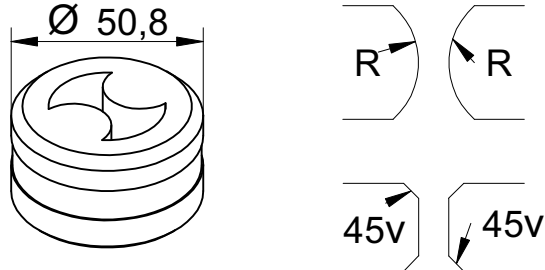
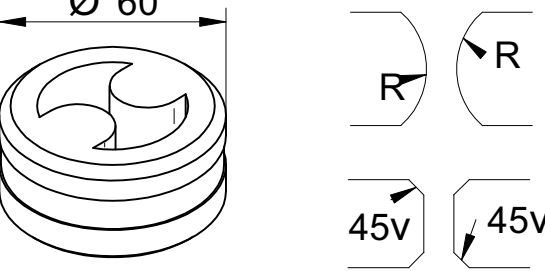
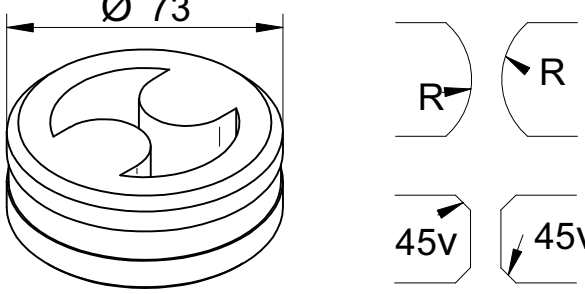
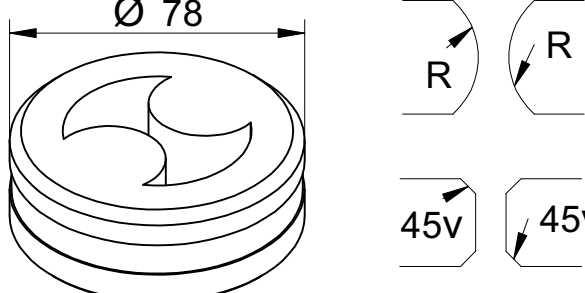
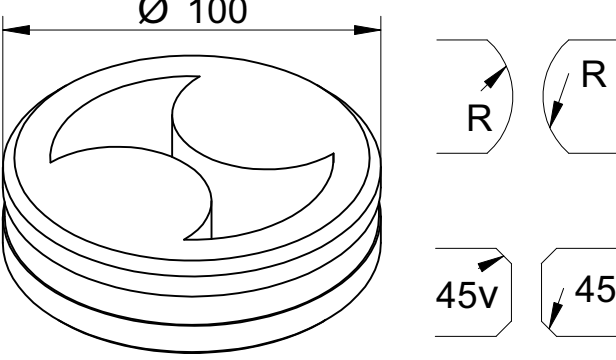
	<p>Rozcinanie i zaokrąglenie (mm)</p> <p>R 5 R 10</p> <p>R 6</p> <p>R 7</p> <p>R 8</p> <p>R 9</p>	<p>NR 5</p>
	<p>Rozcinanie i zaokrąglenie (mm)</p> <p>R 5 R 10 R 15</p> <p>R 6 R 11</p> <p>R 7 R 12</p> <p>R 8 R 13</p> <p>R 9 R 14</p>	<p>NR 8/31</p>
	<p>Rozcinanie i zaokrąglenie (mm)</p> <p>R 5 R 10 R 15</p> <p>R 6 R 11</p> <p>R 7 R 12</p> <p>R 8 R 13</p> <p>R 9 R 14</p>	<p>NR 8/40</p>
	<p>Rozcinanie i zaokrąglenie (mm)</p> <p>R 5 R 10 R 16</p> <p>R 6 R 11 R 17</p> <p>R 7 R 12 R 18</p> <p>R 8 R 13 R 19</p> <p>R 9 R 14 R 20</p> <p>R 10 R 15</p>	<p>NR 11</p>
	<p>Rozcinanie i zaokrąglenie (mm)</p> <p>R 5 R 10 R 16 R 22</p> <p>R 6 R 11 R 17 R 23</p> <p>R 7 R 12 R 18 R 24</p> <p>R 8 R 13 R 19 R 25</p> <p>R 9 R 14 R 20 R 26</p> <p>R 10 R 15 R 21 R 27</p>	<p>NR 12</p> <p>NR 13</p>

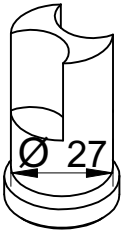
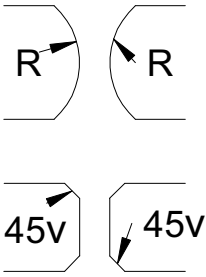
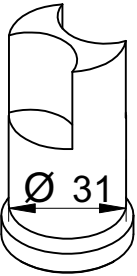
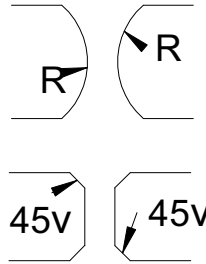
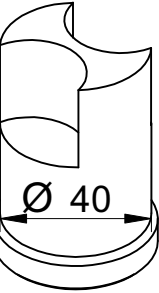
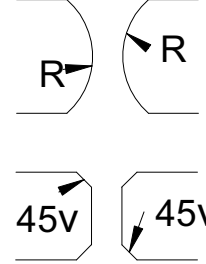
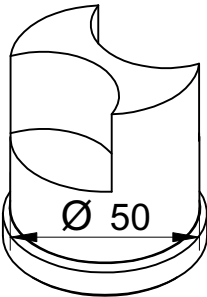
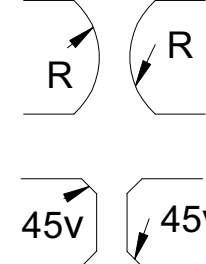
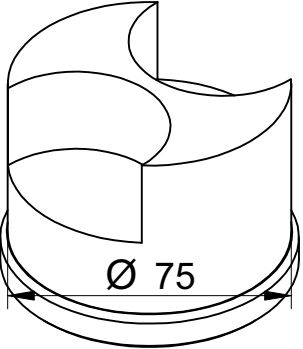
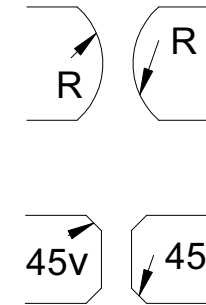
 	<p>Rozcinanie i zaokrąglenie (mm)</p> <p>R 5 R 10 R 6 R 7 R 8 R 9</p>	<p>NR 5</p>
 	<p>Rozcinanie i zaokrąglenie (mm)</p> <p>R 5 R 10 R 15 R 6 R 11 R 7 R 12 R 8 R 13 R 9 R 14</p>	<p>NR 8/31</p>
 	<p>Rozcinanie i zaokrąglenie (mm)</p> <p>R 5 R 10 R 15 R 6 R 11 R 7 R 12 R 8 R 13 R 9 R 14</p>	<p>NR 8/40</p>
 	<p>Rozcinanie i zaokrąglenie (mm)</p> <p>R 5 R 10 R 16 R 6 R 11 R 17 R 7 R 12 R 18 R 8 R 13 R 19 R 9 R 14 R 20 R 10 R 15</p>	<p>NR 11</p>
 	<p>Rozcinanie i zaokrąglenie (mm)</p> <p>R 5 R 10 R 16 R 22 R 6 R 11 R 17 R 23 R 7 R 12 R 18 R 24 R 8 R 13 R 19 R 25 R 9 R 14 R 20 R 26 R 10 R 15 R 21 R 27</p>	<p>NR 12 NR 13</p>

Narzędzia specjalne

Istnieje możliwość wykonania stempli i matryc o specjalnych wymiarach, z indywidualnym luzem.
Wykonanie na podstawie szkicu lub rysunku.

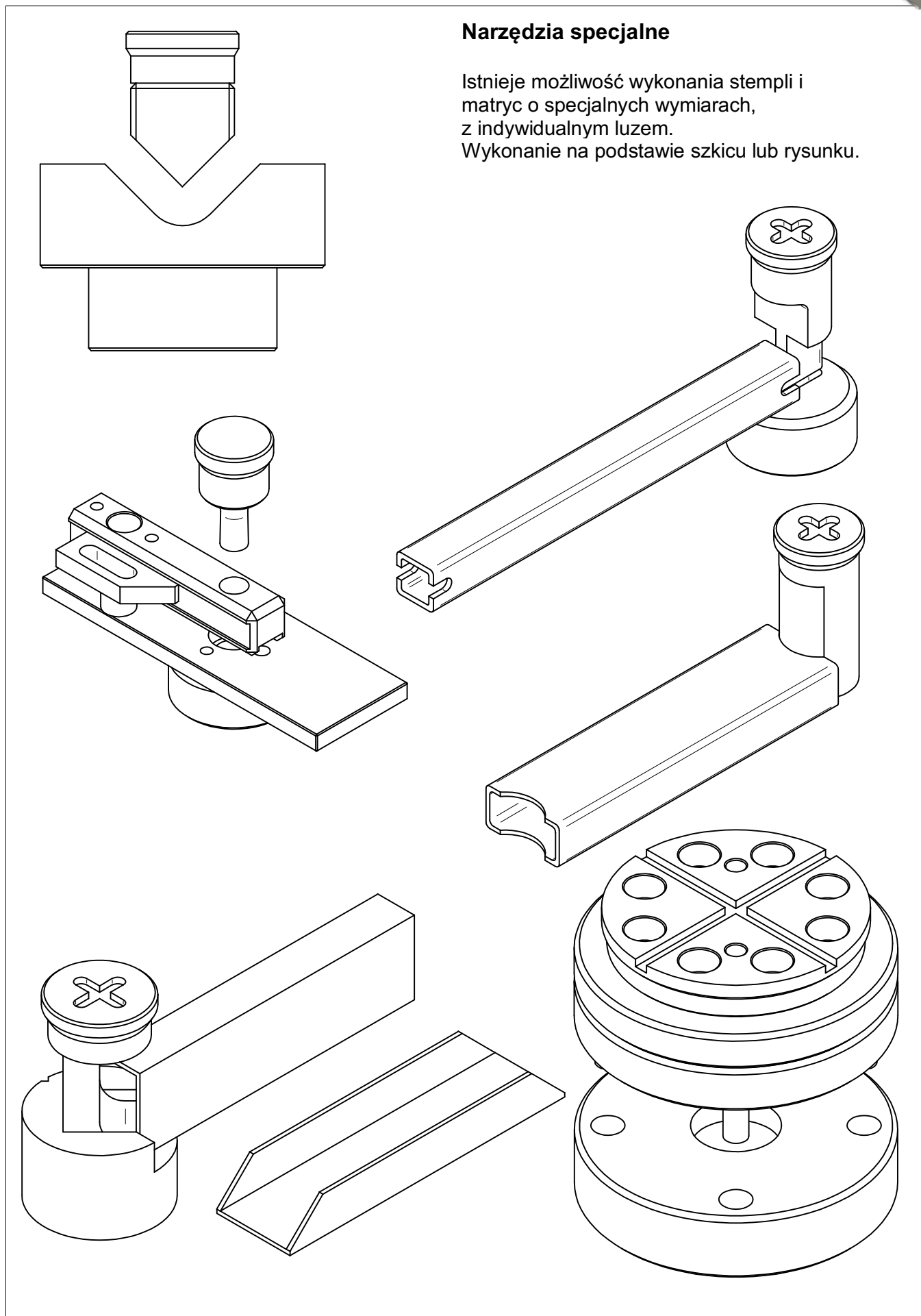

Narzędzia specjalne

Istnieje możliwość wykonania stempli i matryc o specjalnych wymiarach, z indywidualnym luzem.
Wykonanie na podstawie szkicu lub rysunku.

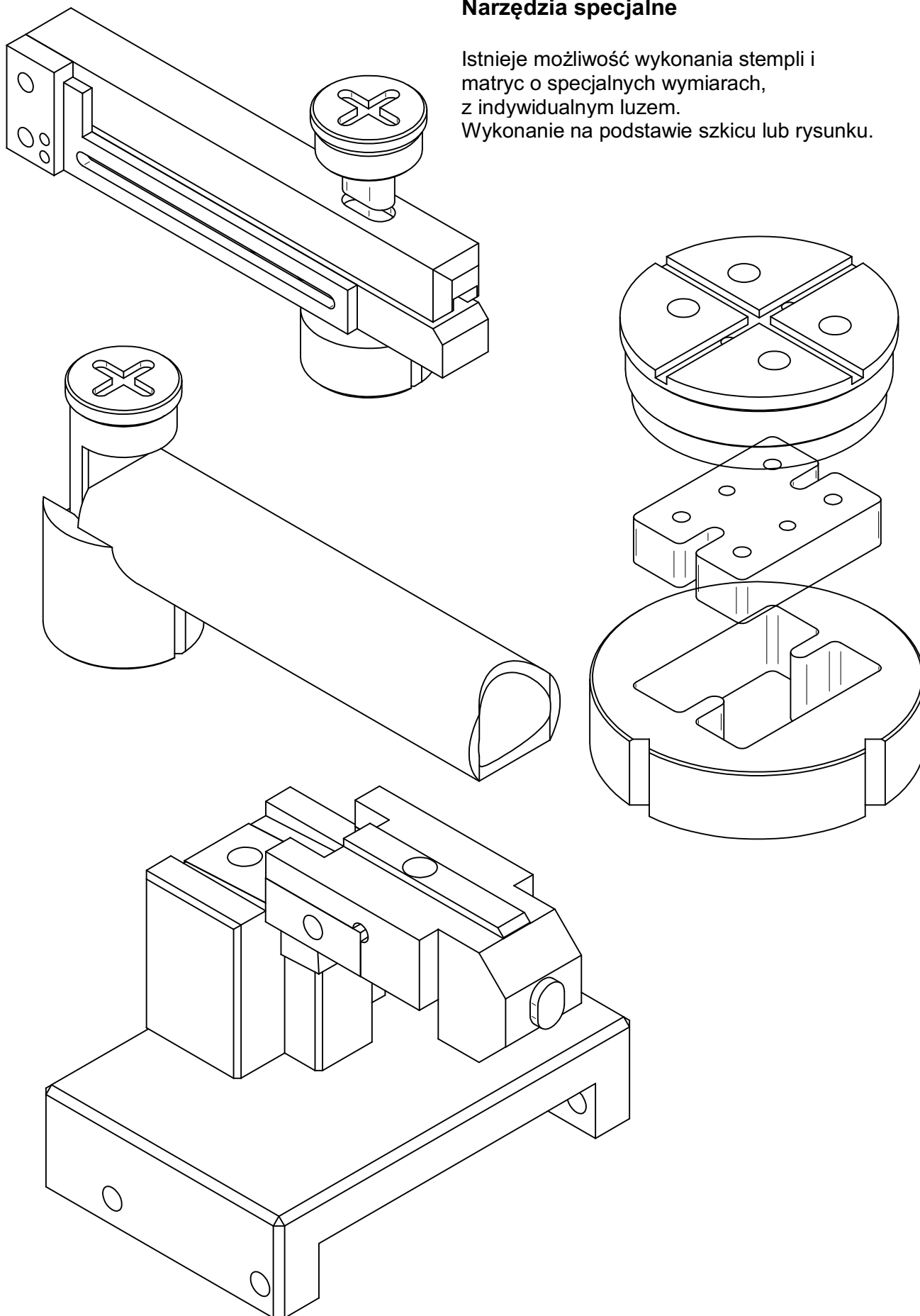

Narzędzia specjalne

Istnieje możliwość wykonania stempli i matryc o specjalnych wymiarach, z indywidualnym luzem.
Wykonanie na podstawie szkicu lub rysunku.

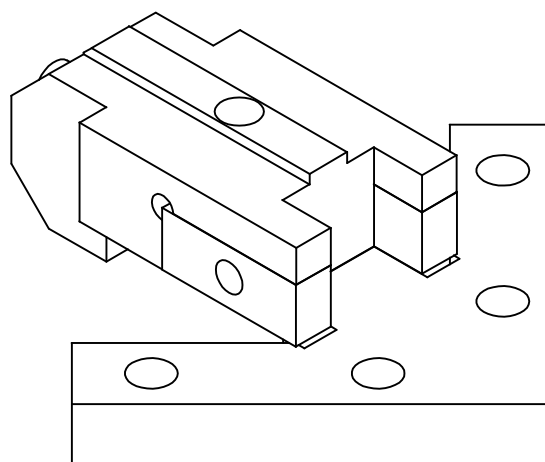
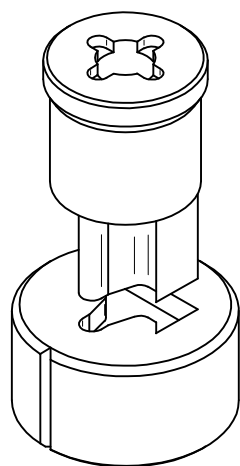
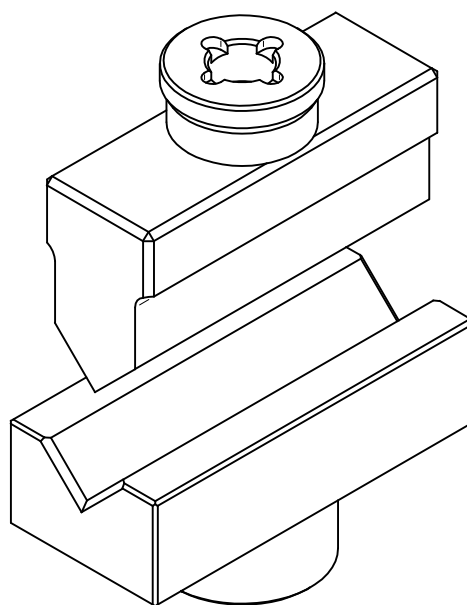
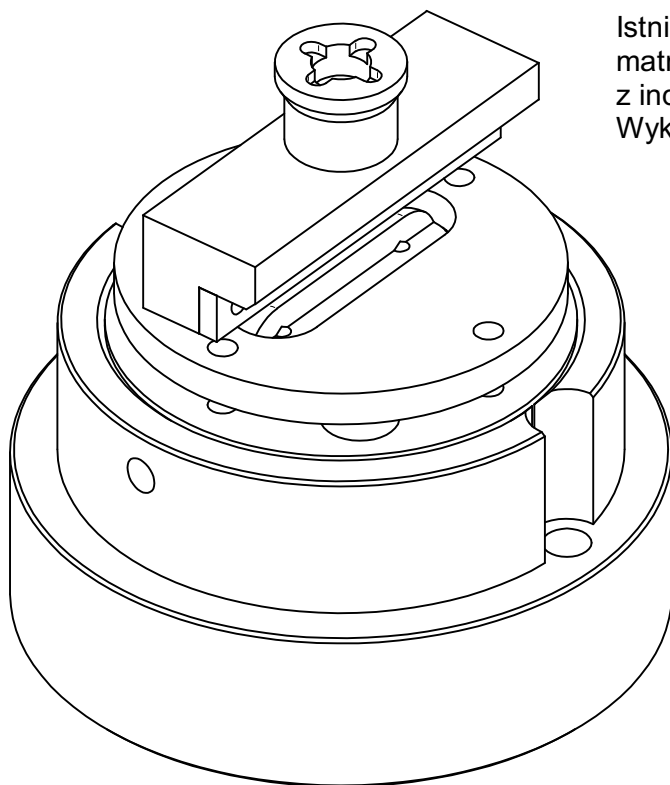



PROJEKTOWANIE I WYKONAWSTWO:

- WYKROJNIKÓW • OKROJNIKÓW • STEPLI I MATRYC DO PRZETŁACZANIA
- STEPLI I MATRYC DO WYCINANIA • OBRÓBKA CNC
- GRAWEROWANIE TECHNICZNE • OBRÓBKA CIEPLNA



WROMET Sp. z o.o.
ul. Kaczeńcowa 2
62-510 Konin

tel. +48 63 245 80 01
info@wromet.com.pl

NIP PL 665-294-89-81
KRS: 000362355